



Vision Cam AI.go

Industrial AI Camera

INDUSTRIAL AI CAMERA

Vision Cam AI.go

Many computer vision tasks are easily formalized and for that traditional systems are usually the right choice. However, they often reach their limits when the defects are hard to formalize. On top of that, the implementation of such systems requires an image-processing specialist. Machine vision systems based on deep learning technologies often offer a better solution. Vision Cam AI.go from IMAGO Technologies is a very flexible complete embedded deep learning based machine vision system. VisionAI.go was mainly developed for end-users with little or no experience in the fields of programming or machine vision. The high flexibility of the deep learning camera Vision Cam AI.go allows the use of the system in numerous industrial areas of application in order to ensure a reliable check of quality features.



Key Features

- Complete embedded deep-learning based machine vision system
- No machine vision skills required
- Intuitive web interface for interaction with human user (HMI)
- Easy handling of parameters and settings
- Simple use of digital Inputs and Outputs

CMOS Sensor – Global Shutter

Optical Size	1/1.8"
Resolution	2560 x 1936 pixels (5 MP)
Pixelsize	(2.8 μm) ²
Framerate (full res.)	65 fps
Partial Scan	yes
Color	mono / color

Interfaces

Ethernet TCP/IP, FTP	1 000 Mbit/s
Digital In/Out	2 x Input / 4 x Output, 24V
Mass Storage	1 x μSD Card \geq 32 GB

Lens Properties

Lens Mount	C-Mount	
Focal length	8mm	16mm
Field of View (H x V)	$\approx 48^\circ \times \approx 36^\circ$	$\approx 24^\circ \times \approx 18^\circ$
M.O.D.	100mm	200mm

Mechanical / Electrical

Ethernet Cable	0.5 m , M12 8 pin
I/O & Power Cable	0.5 m , M12 8 pin
Min. Cable Bending Radius	30 mm (recommended)
Power Supply	24 V _{DC} (21 V _{DC} – 28 V _{DC})
Supply Current @24V	0.5 A
Dimension W × D × H	50 mm × 85mm × 50 mm
Weight	370 g (incl. cable, lens and tube)
Temperature Range	+5 °C ... +40 °C
Mounting	4 × M4 (Back) , 2 x M4 (Top)

Dimensional Drawing

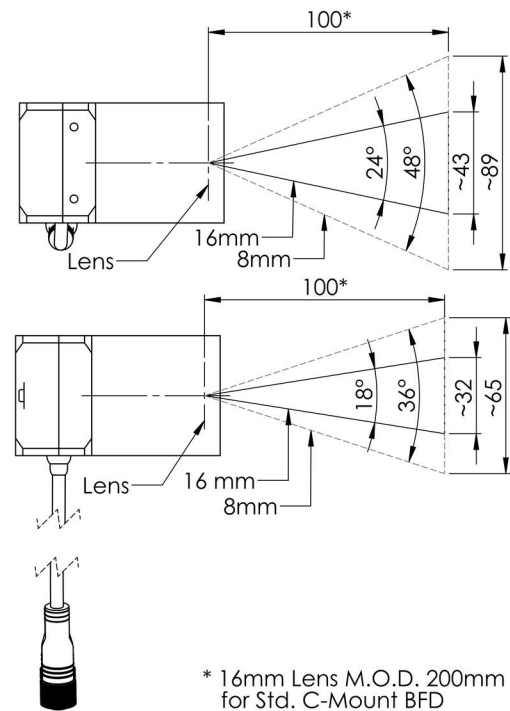
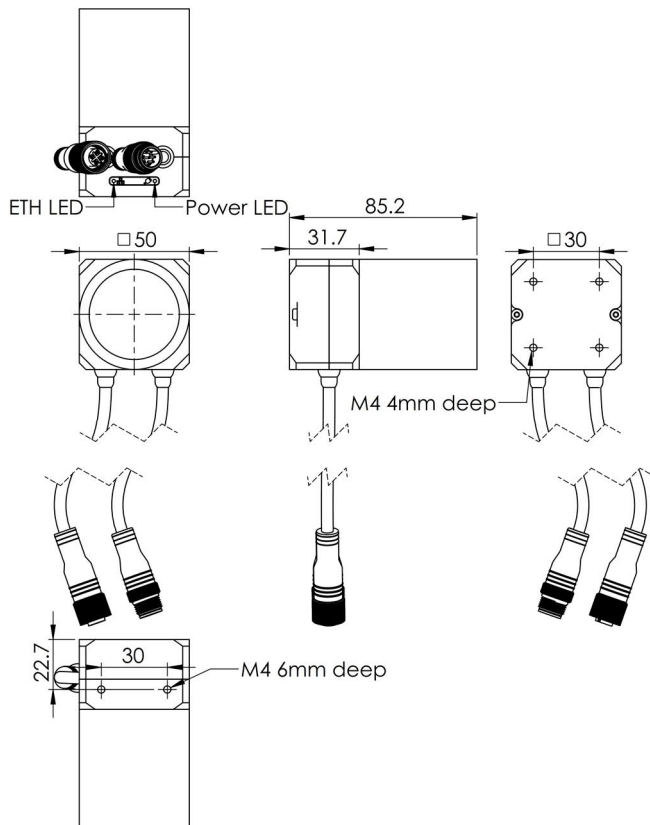

The smartest embedded vision components

For more than 25 years, IMAGO has been supplying machine vision technology to machine builders to improve product quality, make processes smoother, avoid production errors, reduce manufacturing costs and make systems more efficient.



What we do

With the focus on what counts for our customers, we develop hardware components for industrial image processing. Be it in factory automation, the printing industry, for the food and beverage industry, pharmaceutical or logistics industry. IMAGO supplies vision systems, smart cameras, vision sensors and the appropriate software for the optimized use of our products. We pay special attention to miniaturization, high frame rates, increasing computing power and environmentally friendly power consumption. These characteristics already distinguish our products today.

And we are proud of them.