



Vision Sensor LM

2K SMART LINE SCAN CAMERA

2K SMART LINE SCAN CAMERA VisionSensor LM

The Vision Sensor LM is a worldwide unique complete line scan vision system in a form factor of a matchbox! The mini smart camera combines line scan technology with intelligent image processing in one product. With its 2k line scan resolution the Vision Sensor LM fits perfectly for image processing tasks that are best solved by using entry level line scan camera systems. With its free programmability and high performance based on ARM processors, the ultra compact industrial camera allows high flexibility in a wide range of applications: from production to pharma, packaging, food and printing. By using IMAGO's ViewIT software platform, development time can be drastically reduced, resulting in higher effectiveness.



Key Features

- Ultra compact and powerful
- Embedded Line Scan Vision System
- 4 integrated LED's
- Line Trigger + Image Trigger
- Digital I/Os: 2 IN / 4 OUT
- ViewIT Software Framework

Sensor Option / CMOS – Global Shutter

Resolution / Scan rate	1920 × 1 @ 15.6 kHz
	1920 × 2 @ 13.8 kHz
	1920 × 4 @ 11.3 kHz
	1920 × 8 @ 8.3 kHz
	1920 × 16 @ 5.4 kHz

Pixelsize (2.8 μm)²

Color mono / color (Bayer)

Processor

Type	Quad Core ARM Cortex-A53
Processor Clock	4 × 1.8 GHz
DDR RAM	2 GB DDR4
Mass Storage	1 × μSD Card ≥ 32 GB

Interfaces

Ethernet TCP/IP, FTP	1 000 Mbit/s
Digital In/Out	2 × Input / 4 × Output, 24 V

Lens Properties

Lens Mount	S-Mount
Focal length	9 mm [others on request]

Mechanical / Electrical

Ethernet Cable	0.5 m, M12 8 pin
I/O & Power Cable	0.5 m, M12 8 pin
Min. Cable Bending Radius	30 mm (recommended)
Power Supply	24 V _{DC} (21 V _{DC} – 28 V _{DC})
Supply Current @24V	0.5 A
Dimension W × D × H	45 mm × 54 mm × 25 mm
Weight	125 g (incl. cable)
Temperature Range	+5 °C ... +40 °C
Mounting	4 × M3

Dimensional Drawing

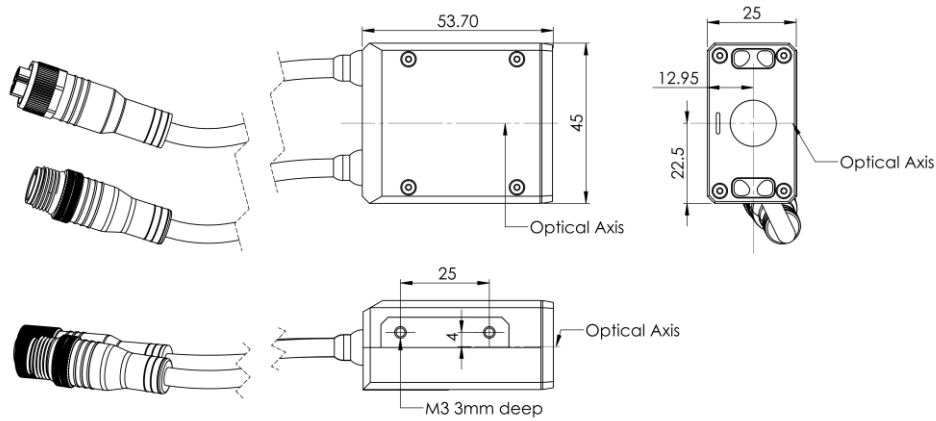

The smartest embedded vision components

For more than 25 years, IMAGO has been supplying machine vision technology to machine builders to improve product quality, make processes smoother, avoid production errors, reduce manufacturing costs and make systems more efficient.



What we do

With the focus on what counts for our customers, we develop hardware components for industrial image processing. Be it in factory automation, the printing industry, for the food and beverage industry, pharmaceutical or logistics industry. IMAGO supplies vision systems, smart cameras, vision sensors and the appropriate software for the optimized use of our products. We pay special attention to miniaturization, high frame rates, increasing computing power and environmentally friendly power consumption. These characteristics already distinguish our products today.

And we are proud of them.