



Hardware Manual

VisionBox AI

Version 1.0 – January 2023

Contents

1	Handling and Safety Instructions	3
2	Introduction	4
2.1	Main features.....	5
2.2	Configurations	6
2.3	Block Diagram.....	7
3	Technical Data.....	8
3.1	Jetson AGX Orin	8
3.2	Operating Conditions	9
3.3	Dimensions.....	11
4	Power Connector and LEDs.....	12
4.1	Power Connector	12
4.2	System LEDs	12
5	Interfaces	13
5.1	RS-232	13
5.2	Ethernet.....	14
5.3	DisplayPort	15
5.4	USB-A 2.0.....	15
5.5	USB-C 3.2.....	15
5.6	Digital I/O	16
5.7	RS-422 Interface.....	18
5.8	Camera Link	19
6	Accessories	20
6.1	Third-party Components.....	20
6.2	IMAGO Accessories	20
7	History	21

1 Handling and Safety Instructions



Depending on the operating conditions, the housing temperature can exceed 60 °C. There is a risk of injury!



Handle with care! The housing, especially heat sinks can have sharp edges. There is a risk of injury!



EMC conformity according to EN/IEC 61000-6-2:2005 is qualified for cable lengths \leq 30 m.

Electrostatic discharge at unshielded I/O connectors can lead to unexpected events or data errors for the corresponding interface.



Electrical installation should be executed without power applied to the device and connected devices.



Only open if advised by IMAGO!

Warranty void if warranty seal is removed or broken.



Please take special note of the **voltage range** which may be applied to the device. Otherwise, permanent damage to the device may result!



Air Circulation

When mounting the device within an enclosure, adequate space for air circulation is required. The space above, below and at both sides should be at least 5 cm.



Avoid extreme environmental conditions and protect the device from dust, humidity and heat.



Due to the characteristics and physical principles inside flash memory, **SSDs have a finite lifetime** dictated by the number of write operations. Therefore, take care of the regular write operations to prevent an early SSD damage. Ask for the technical data of the used SSD and, if necessary, for support to calculate the lifetime. Inform the user of the system that SSDs are wear parts which must be renewed regularly.

2 Introduction

The heart of the VisionBox AI is the powerful NVIDIA Jetson AGX Orin. It comes with up to 12 Arm cores and 2048 CUDA cores. We deliver the VisionBox with an Ubuntu based Linux OS, which gives the customer the ability to use the popular Linux programs, libraries and development tools.

The VisionBox AI provides four Gigabit Ethernet ports and a Camera Link interface. Two Camera Link connectors can be used with two cameras in Base configuration, or one camera in Medium, Full or Deca configuration.

The integrated Real-Time Communication Controller (*RTCC*) ensures proper timing for trigger signals, independently from the operating system. The IMAGO SDK provides a consistent C++ programming interface for controlling the *RTCC*.

Due to its small size, powered by 24V_{DC} and without fan, the VisionBox can be mounted into nearly every machine. All components are available for several years for continuous delivery without changes. For series production, IMAGO delivers the VisionBox ready-to-run, including a customer-specific Linux root filesystem, qualified 3rd-party components and acceptance test. A PREEMPT_RT kernel is also available.

2.1 Main features

- NVIDIA AGX Orin
 - 8 or 12-core Arm® Cortex®-A78AE v8.2 64-bit CPU
 - NVIDIA Ampere architecture with up to 2048 NVIDIA® CUDA® cores and 64 Tensor Cores
 - Up to 64 GB RAM
 - 64 GB eMMC flash
- Real-Time Communication Controller *RTCC*:
 - Controls vision- & automation-specific interfaces:
 - Digital I/Os
 - Encoder
 - Camera trigger
 - Contains functional units for controlling I/Os in real time:
 - Trigger unit: Creation of trigger signals, derived from other inputs (e.g. encoder)
 - I/O scheduler: applies values stored in a FIFO to outputs in real time (based on trigger event, encoder position, or timer value)
 - Multiplexer: flexible connection of functional units
 - Operates independently from the OS and the CPU
 - Easy-to-use high-level API for C++ and Python
- Interfaces
 - 4x Gigabit Ethernet
 - Camera Link:
Support for two cameras in Base configuration or one camera in Medium, Full or Deca configuration
 - 1x USB-C 3.2 Gen 2
 - 2x USB-A 2.0
 - 1x RS-232
 - Digital I/Os:
 - Isolated inputs and outputs
 - Inputs with adjustable debouncing with *RTCC*
 - Status LEDs
 - RS-422 I/O optionally, e.g. for encoders
- Housing
 - Passive cooling
 - All interfaces on front panel
 - 24 V DC power input
 - No moving parts

2.2 Configurations

The following table shows available features and interfaces for the VisionBox AI:

Storage	64 GB eMMC SD card M.2 2280 M-key (option)
USB	1× USB-C 3.2 Gen 2 2× USB-A 2.0
Display	DisplayPort 1.4a
Ethernet	4× 1GbE
Camera Interface	Camera Link: 2× Base or 1× Medium / Full / Deca configuration
Dig. I/Os	8× IN / 8× OUT optionally 16× IN / 16× OUT
UART	1× RS-232
Encoder / RS-422	One or two connectors with 3× IN and 3× OUT for each

Table 1: Feature overview

Please also ask for OEM configurations.

2.3 Block Diagram

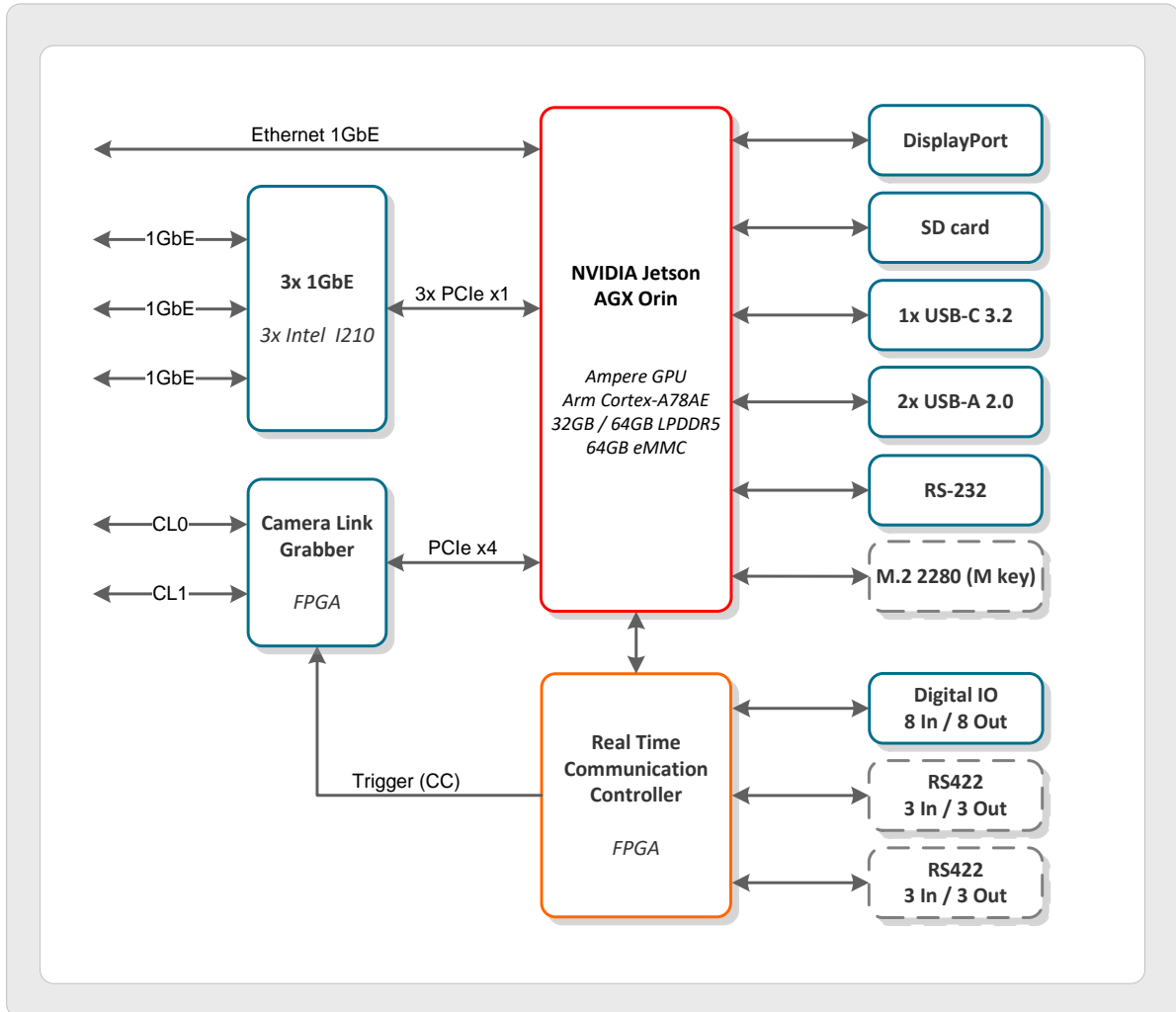

Figure 1: Block diagram

3 Technical Data

3.1 Jetson AGX Orin

The following Jetson AGX Orin models are available for the VisionBox AI:

	Jetson AGX Orin 32GB	Jetson AGX Orin 64GB
CPU	8-core Arm® Cortex®-A78AE v8.2 64-bit, 2.2 GHz	12-core Arm® Cortex®-A78AE v8.2 64-bit, 2.2 GHz
GPU	NVIDIA Ampere architecture 1792 NVIDIA® CUDA® cores 56 Tensor Cores 939 MHz	NVIDIA Ampere architecture 2048 NVIDIA® CUDA® cores 64 Tensor Cores 1.3 GHz
DL Accelerator	2x NVDLA v2.0, 1.4 GHz	2x NVDLA v2.0, 1.6 GHz
Vision Accelerator	PVA v2.0	
Memory	32 GB 256-bit LPDDR5, 204.8 GB/s	64 GB 256-bit LPDDR5, 204.8 GB/s
Storage	64 GB eMMC 5.1	
Real-Time Clock	Powered by lithium coin cell	
Module power limit	40 W	60 W

Table 2: Jetson AGX Orin models

3.2 Operating Conditions

Power supply:

Parameter		Orin 32GB	Orin 64GB	Unit
Supply voltage		18...30		V
Typical power consumption ¹	CPU: idle, GPU: idle	≈ 16	tbd	W
	CPU: 100%, GPU: idle	≈ 26	tbd	W
	CPU: 100%, GPU: 95%	≈ 38	tbd	W
Power supply current rating (value for 24 V supply)		2	tbd	A

Environment:

Parameter	Value	Unit
Operating temperature	tbd	°C
Operating humidity, relative, non-condensing	5 ... 85	%
Storage temperature	-10 ... +70	°C
Storage humidity, relative, non-condensing	5 ... 95	%
Device weight	2.2	kg

Note: The maximum allowed temperature is influenced by the actual hardware configuration, the system workload, and the mounting situation. The temperature range should be verified for each application.

¹ The actual power draw heavily depends on the application. Power supply and cooling requirements should be evaluated by the user.

RS-232:

Parameter	Min	Typ.	Max	Unit
RX input voltage range	- 25		25	V
TX output voltage swing (RL = 3 kΩ)	± 5	± 5.4		V
Data rate, RL = 3 kΩ, CL = 1 nF			250	kbps

Digital Input:

Parameter	Min.	Typ.	Max.	Unit
Input voltage range	0		30	V
Input Maximum Current range (limited by internal circuit)	0		21	mA
Threshold Voltage	6		11	V
Threshold current		1	5	mA
Input delay			250	ns

Digital Output:

Parameter	Min.	Typ.	Max.	Unit
Common VCC Supply Voltage ($V_{CEC} - V_{OUT}$)	0		30	V
Output Current, Saturated Operation ($V_{CEC} - V_{OUT} < 1 V$)			10	mA
Turn-On Time (24 V Common VCC, 10 mA)		5		μs
Turn-Off Time (24 V Common VCC, 10 mA)		15		μs

RS-422:

Parameter	Min.	Typ.	Max.	Unit
Receiver differential input threshold	-200		200	mV
Receiver input hysteresis		45		mV
Receiver data rate			10	Mbps
Transmitter differential driver output, RL = 100 Ω	2			V
Transmitter differential driver output, open			3.3	V
Transmitter data rate			2	Mbps
5V encoder supply output current			500	mA

3.3 Dimensions

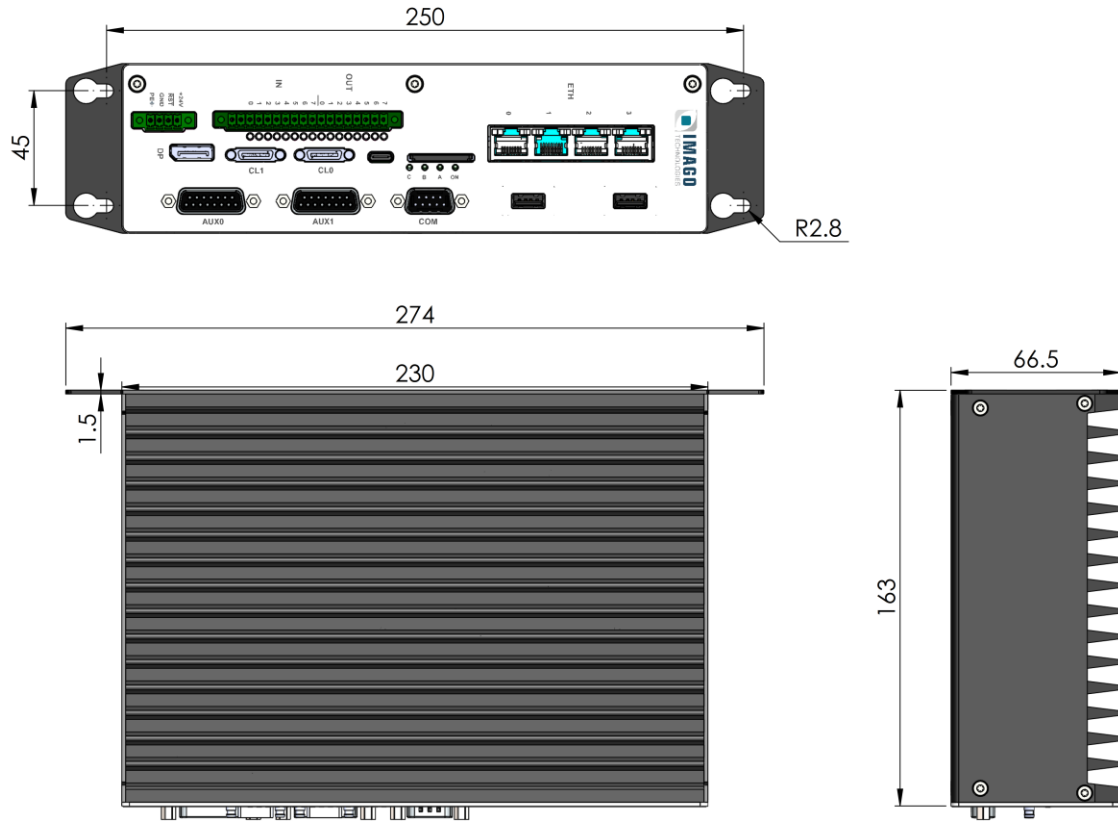
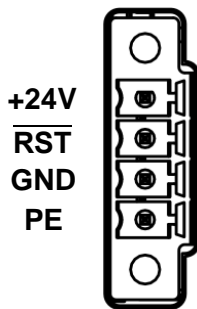

Figure 2: Housing dimensions (in mm)

4 Power Connector and LEDs

4.1 Power Connector



Pin	Function
+24V	24 V power supply
RST	Reset input, low active
GND	Ground (power / signals)
PE	Earth / housing connection

Table 3: Power connector

Figure 3: Power plug

The VisionBox does not connect ground and the housing with each other to avoid ground loops with other connected devices. It is good practice to connect them at a single point in the facility.

The $\overline{\text{RST}}$ terminal can be pulled to GND to reset the VisionBox during operation. A falling edge will trigger the reset. Leaving the signal floating is the default mode for normal operation.

Phoenix Contact plug component: **MC 1,5/4-STF-3,5** (order no. 1847071)

4.2 System LEDs

The computer has four main system LEDs. These LEDs are dual color (bicolor) types. The functionality of the LED A, B and C can be changed by software.



Figure 4: Status LEDs

LED	Color	Function
ON	Green	Power On
	Green blinking	USB recovery mode
	Red	FPGA configuration error
	Orange	System shutdown or reset
A	Green	User LED 0
	Red	User LED 1
B	Green	User LED 2
	Red	User LED 3
C	Green	User LED 4
	Red	User LED 5

Table 4: System LED values

5 Interfaces

This chapter describes the interfaces for the VisionBox AI.

5.1 RS-232

A male 9-pin D-sub connector provides one RS-232 UART without flow control.

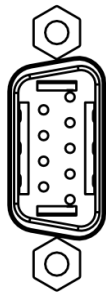

Figure 5: RS-232 D-sub connector

Pin	Function
1	N/C
2	RX
3	TX
4	N/C
5	GND
6	N/C
7	N/C
8	N/C
9	N/C

The TX and RX signals use the GND pin as reference potential. Make sure that the remote device uses the same GND reference.

The RS-232 interface is normally used as additional console device for Linux. A null modem cable is required to connect the VisionBox to a PC. It can also be configured for use by custom applications.

Default settings for the serial interface:

Parameter	Value
Baud rate	115200 bps
Parity	None
Data bits	8
Stop bits	1
Flow control	None

5.2 Ethernet

The VisionBox AI comes with four Gigabit Ethernet ports. The first port is implemented using the integrated NVIDIA Jetson Ethernet controller, while the other ports use the Intel I210 controller.

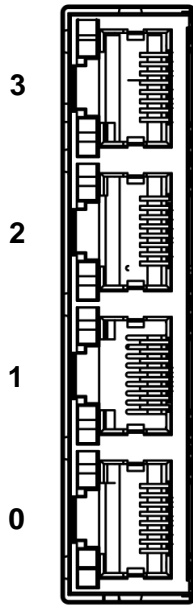

Figure 6: Ethernet connector

Assignment of the status LEDs for each port:

State	Upper LED
No traffic	Off
Traffic	Blinking

Table 5: Upper LEDs

Link speed	ETH0	ETH1...ETH3
10 Mbit/s	Green	Off
100 Mbit/s	Green	Off
1000 Mbit/s	Green	Green

Table 6: Lower LEDs

5.3 DisplayPort



Figure 7: DP connector

The DisplayPort interface supports version 1.4a with a data rate of 32.4 Gbit/s. The maximum supported resolution is 8K60. To connect the DP Port with a DVI or VGA monitor, an active adapter is required.

5.4 USB-A 2.0

The VisionBox AI provides two USB 2.0 Type-A connectors:



Figure 8: USB 2.0 Type-A connector

Based on the USB 2.0 specification, each port can deliver 500 mA.

5.5 USB-C 3.2

The USB Type-C connector provides SuperSpeed+ transfer mode (USB 3.2 Gen 2) with up to 10 Gbit/s.

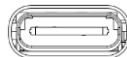

Figure 9: USB Type-C connector

The USB-C port can deliver up to 900 mA.



If a PC is connected to the USB-C port during power on, the VisionBox enters USB recovery mode. This is indicated by a green blinking ON LED. Only use this mode if advised by IMAGO. Do not try to flash the Jetson OS image provided by NVIDIA!

5.6 Digital I/O

The digital I/O interface provides an input and an output group. Each group has eight signals, and all groups are electrically isolated from each other, as well as from other VisionBox circuits and interfaces.

The following illustration shows the corresponding electrical equivalent circuit for one input and one output group:

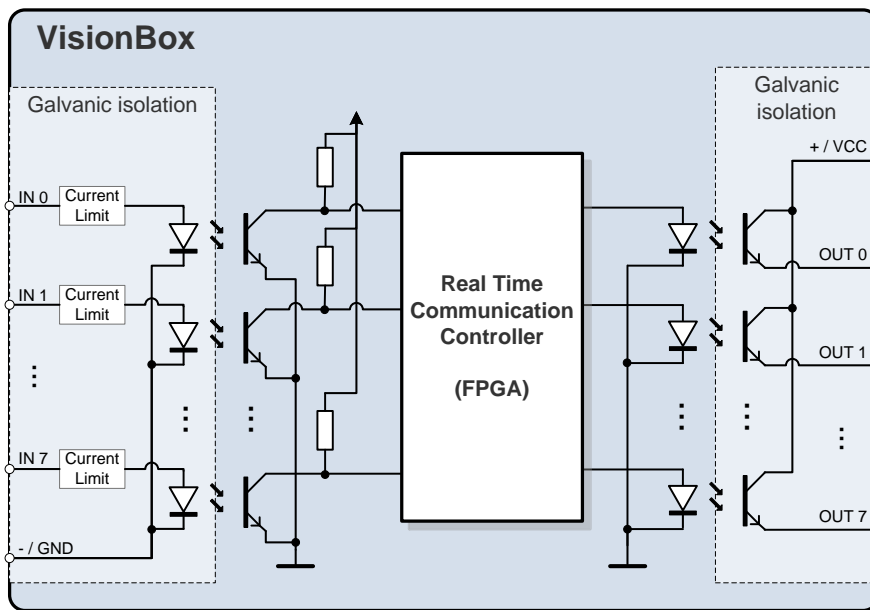

Figure 10: Simplified digital I/O circuit

The input group requires external connection of a shared GND reference. For the output group, the user must provide a supply voltage to the VCC pin which is used by all output signals. Every input and output have an LED to show the current state of each channel.

The connector arrangement is shown below:

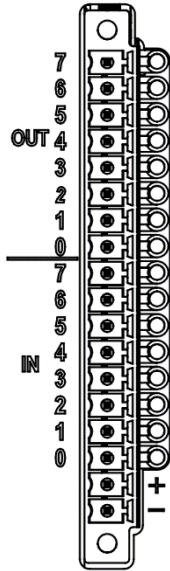

Figure 11: Digital I/O connector

Pin	Function
1	OUT7
2	OUT6
3	OUT5
4	OUT4
5	OUT3
6	OUT2
7	OUT1
8	OUT0
17	+ / Common VCC of outputs

Pin	Function
9	IN7
10	IN6
11	IN5
12	IN4
13	IN3
14	IN2
15	IN1
16	IN0
18	- / Common GND of inputs

Table 7: Pin assignment dig. I/O

External plug component: Phoenix contact **MC 1,5/18-STF-3,5** (order no. 1847288)

5.7 RS-422 Interface

The RS-422 interface can be used to connect additional devices like encoders, sensors and cameras. The behavior is controlled by the Real-Time Communication Controller.

The female 15-pin D-sub connector provides three input and three output signals:

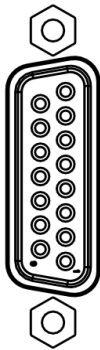

Figure 12: RS-422 connector

Pin	Function
1	GND
2	OUT2+
3	OUT1+
4	OUT0+
5	IN2+
6	IN1+
7	IN0+
8	5V DC output
9	OUT2-
10	OUT1-
11	OUT0-
12	IN2-
13	IN1-
14	IN0-
15	GND

Table 8: RS-422 pin assignment

Pins 8 provides a 5 V power supply for RS-422 encoders.

The input and output signals use the GND pins as reference potential. Make sure that connected devices use the same GND reference.

5.8 Camera Link

The VisionBox AI has two Mini Camera Link connectors:



Figure 13: Mini Camera Link connectors

The Camera Link interface supports the following features:

- Camera Link Dual-Base configuration:
 - 2x Base / 1x Medium Camera Input
 - 2x Serial communication interface
- Camera Link Full / Deca configuration:
 - 1x Base / 1x Medium / 1x Full / 1x Deca Camera Input
 - 1x Serial communication interface
- Camera Control signals (CC) can be controlled by software or by the RTCC.

A different FPGA firmware is used to select between Dual-Base and Full configuration.

6 Accessories

This list shows some compatible connectors, shells and plugs to support the device interfaces. Typically, the plugs are not included in the device package.

6.1 Third-party Components

Vendor	Type	Part Number	Usage
Phoenix	MC 1,5 / 4-STF-3,5	1847071	Power connector
Phoenix	MC 1,5 / 18-STF-3,5	1847288	Digital In / Out

There is also a connector set with plugs available. Please refer to the following table or ask for more details.

6.2 IMAGO Accessories

Order Number	Description
10005154	Connector set: 1x 4 Pin power connector, 1x 18 Pin I/O

More accessories and upgrades are available upon request.

7 History

Revision	Date	Changes	Initials
1.0	23.01.2023	First version	rg