



Vision Cam XM2 Line Scan

SMART LINE SCAN CAMERA

SMART LINE SCAN CAMERA

Vision Cam XM2 Line Scan

The Vision Cam XM2 Line Scan is an intelligent, embedded line scan camera system that combines line scan camera technology, intelligent image processing and AI vision in one product. It is freely programmable and runs on the Linux Ubuntu operating system. The camera offers high computing power in a compact camera format thanks to the NVidia ORIN-platform. With a sensor of 2.5k resolution and free programmability, the Vision Cam XM2 Line Scan is ideal for image processing tasks in various fields. The camera is compact (113 x 50 mm) and offers interfaces such as Gigabit Ethernet and digital IOs. It enables the execution of rule-based and AI algorithms as well as the development of applications with the ViewIT software platform.

Key Features

- Sensor Trigger
- Digital I/Os with opto-isolators: 4 IN / 4 OUT
- Monochrome 2.5K line scan
- Serial Interface and 1 Gigabit/s Ethernet
- Free programmable under Ubuntu
- Fast developing with IMAGO's ViewIT available
- Encoder



Sensor Option / CMOS - Global Shutter

Resolution / Scan rate	2560 × 1 @ 28.3 kHz 2560 × 2 @ 56.5 kHz 2560 × 4 @ 97 kHz 2560 × 8 @ 150.9 kHz 2560 × 16 @ 209 kHz
------------------------	--

Pixel Size	5 µm
Color	mono

Processor / Storage

Type	NVIDIA ORIN NANO ARM Cortex A78AE
Processor Clock	6 x 1.5 GHz
GPU	1024-core NVIDIA Ampere GPU
DDR RAM	8 GB LPDDR5 68 GB/s
Mass Storage	NVMe SSD ≥ 60 GB

Interfaces

Ethernet	1000 Mbit/s
Serial Interface	1 × RS-232
Digital In/Out	2 × Input & 4 × Output, 24V
Encoder	RS-422 Inputs

Lens Property

Lens Mount C-Mount

Mechanical / Electrical

Dimension L x W x D without lens	120 mm x 56 mm x 50 mm
Dimension L x W x D with tube	120 mm x 56 mm x (57mm - 110 mm)
Weight (without lens)	314 g (without encoder)
Temperature Range	+5 °C ... +45 °C
Ethernet Connector	M12 - 8 Pin
I/O Connector	M12 - 17 Pin
Power Supply	11 VDC – 26 VDC (light requires ≈ 24 V)
Mounting	4 x M4

Dimensional Drawing

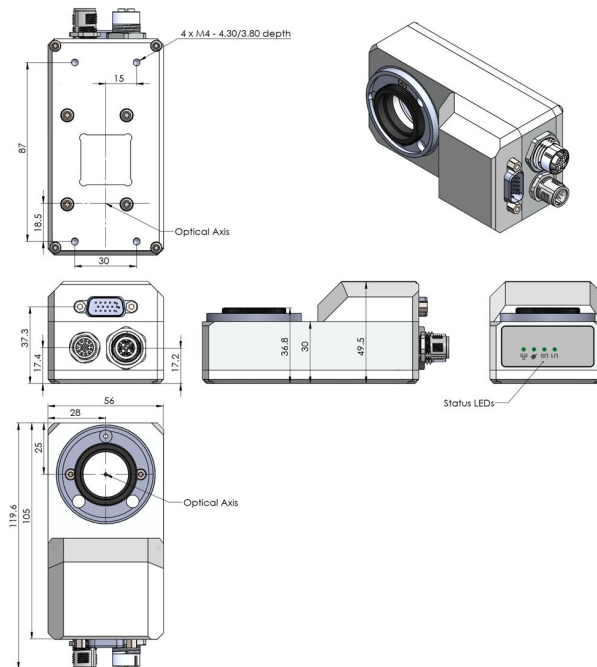

The smartest embedded vision components

For more than 30 years, IMAGO has been supplying machine vision technology to machine builders to improve product quality, make processes smoother, avoid production errors, reduce manufacturing costs and make systems more efficient.



What we do

With the focus on what counts for our customers, we develop hardware components for industrial image processing. Be it in factory automation, the printing industry, for the food and beverage industry, pharmaceutical or logistics industry. IMAGO supplies vision systems, smart cameras, vision sensors and the appropriate software for the optimized use of our products. We pay special attention to miniaturization, high frame rates, increasing computing power and environmentally friendly power consumption. These characteristics already distinguish our products today.

And we are proud of them.