



Vision Cam LM2

SMART LINE SCAN CAMERA

SMART LINE SCAN CAMERA

Vision Cam LM2

The Vision Cam LM2 is an intelligent, freely programmable line scan camera. Multi-core ARM and GPUs provide high computing power. IMAGO's unique Real-Time Communication Controller (RTCC) provides user-programmable logic and internal units for I/Os. As it operates independent from the operating system many time-critical applications can be realized without using a real-time operating system. NVIDIA ORIN Nano/NX featuring 6-core/8-Core ARM-based CPU and a powerful GPU runs under Ubuntu, providing developers a powerful basis for quick applications in C++ or other languages.

Key Features

- Up to 210 kHz
- 4k line scan RGB+Mono in one sensor
- Nvidia 6/8 core CPU and 1024 core GPU
- Freely programmable under Ubuntu
- Digital I/Os



Processor

Type	NVIDIA ORIN NANO ARM Cortex A78AE	NVIDIA ORIN NX ARM Cortex A78AE	NVIDIA ORIN NX ARM Cortex A78AE
Processor Clock	6 x 1.5 GHz	8 x 2 GHz	8 x 2 GHz
GPU	1024-core NVIDIA Ampere GPU	1024-core NVIDIA Ampere GPU	1024-core NVIDIA Ampere GPU
DDR RAM	8 GB LPDDR5 68 GB/s	8 GB LPDDR5 102 GB/s	16 GB LPDDR5 102 GB/s
Mass Storage	NVMe SSD ≥ 60 GB	NVMe SSD ≥ 60 GB	NVMe SSD ≥ 60 GB

Interfaces

Ethernet	1000 MBit/s	1000 MBit/s
Digital In/Out	4 x Input / 4 x Output, opto-isolated, 24V	4 x Input / 4 x Output, opto-isolated, 24V
Serial Interface	1 x RS-232 2 x RS-422 Input 2x RS-422 Output	1 x RS-232, 4 x RS422 Input
LVDS	1 x Input	-
Encoder	-	RS-422 inputs

Sensor

Optical Size	1.8"
Resolution	4 x 4096
Pixel Size	7 µm
Line Rate	up to 210 kHz
Color	Color and Mono: R+G+B+mono

Mechanical / Electrical

Power Supply	18 VDC – 30 VDC (light requires \approx 24 V)
Dimension W x H x D	60 mm x 105 mm x 64 mm
Weight	650 g
Ethernet Connector	M12 - 8 Pin
I/O Connector	M12 - 17 Pin
Additional Connector	D-Sub 15 HD
Mounting	4 x M4

Documentation

Homepage	Link
SDK Documentation	Link
Hardware Manual	Link

Dimensional Drawing

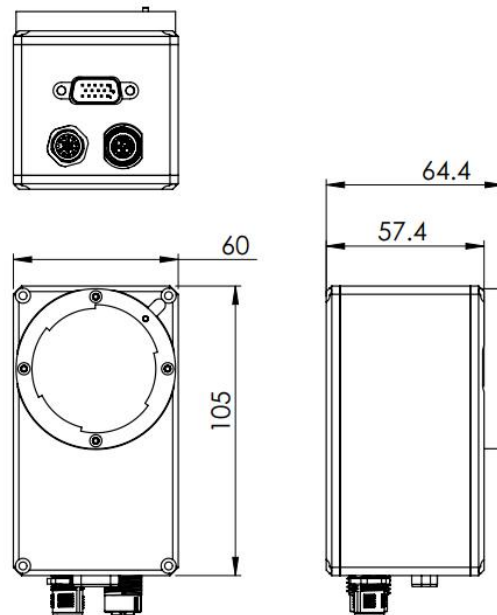

The smartest embedded vision components

For more than 30 years, IMAGO has been supplying machine vision technology to machine builders to improve product quality, make processes smoother, avoid production errors, reduce manufacturing costs and make systems more efficient.



What we do

With the focus on what counts for our customers, we develop hardware components for industrial image processing. Be it in factory automation, the printing industry, for the food and beverage industry, pharmaceutical or logistics industry. IMAGO supplies vision systems, smart cameras, vision sensors and the appropriate software for the optimized use of our products. We pay special attention to miniaturization, high frame rates, increasing computing power and environmentally friendly power consumption. These characteristics already distinguish our products today.

And we are proud of them.