



# Industrial DashCam 1000

High-Speed condition monitoring camera

## High-Speed condition monitoring camera

# Industrial DashCam 1000

The Industrial DashCam 1 000 is a powerful standalone system that can be easily integrated into existing environments. It provides real-time video footage of your industrial processes, so you can troubleshoot problems quickly and easily. The camera features a ring buffer, so it can continuously record footage. It also has various trigger modes, so you can also record footage only when certain events occur. The Industrial DashCam 1 000 is designed for in-service diagnostics and remote analysis, and it helps to improve the reliability and availability of systems.

### Key Features

- Powerful Standalone System
- Easy integration in existing environments with REST API
- Diagnostic during operation
- Remote analysis
- Intuitive web interface for interaction with human user (HMI)
- Various Trigger modes
- Auto Trigger for easy automation
- Easy handling of parameters and settings
- 5 Megapixel



### Processor

Type	NVIDIA ORIN NX ARM Cortex A78AE
Processor Clock	8 x 2 GHz
GPU	1024-core NVIDIA Ampere GPU
DDR RAM	16 GB LPDDR5 102 GB/s
Mass Storage	NVMe SSD ≥ 240 GB

### Interfaces

Ethernet	1000 Mbit/s
Digital In/Out	4 x Input & 4 x Output (24V)
Serial Interface	1 x RS-232

### Sensor

Optical Size	1"
Resolution	2560 x 2048 pixels
Pixel Size	5 µm
Framerate	165 fps
Partial Scan	yes
Color	mono

### Lens Properties

Lens Mount	C-Mount	C-Mount
Focal length	-	12 - 36 mm
Aperture	-	F 1,6

### Mechanical / Electrical

Power Supply	11 VDC – 26 VDC (light requires ≈ 24 V)	11 VDC – 26 VDC (light requires ≈ 24 V)
Dimension W × H × D	56 mm x 120 mm x 30 mm	56 mm x 120 mm x 30 mm
Weight	341 g	935 g
Temperature Range	+5 °C ... +45 °C	+5 °C ... +45 °C
Ethernet Connector	M12 - 8 Pin	M12 - 8 Pin
I/O Connector	M12 - 17 Pin	M12 - 17 Pin
Certification	IP50, CE	IP50, CE
Mounting	4 x M4	4 x M4

### Framerate

FULL HD	≈ 415 fps
VGA	≈ 1400 fps
QVGA	≈ 2730 fps

### Documentation

Homepage	<a href="#">Link</a>
SDK Documentation	<a href="#">Link</a>
Hardware Manual	<a href="#">Link</a>

### Dimensional Drawing

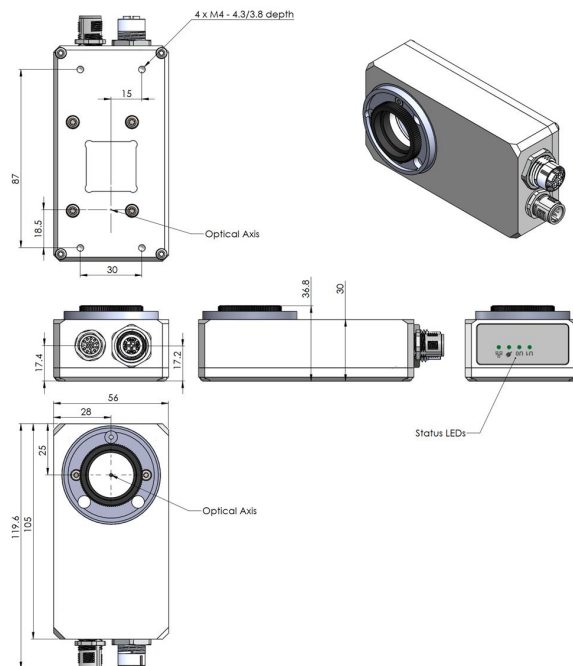

# The smartest embedded vision components

For more than 30 years, IMAGO has been supplying machine vision technology to machine builders to improve product quality, make processes smoother, avoid production errors, reduce manufacturing costs and make systems more efficient.



## **What we do**

With the focus on what counts for our customers, we develop hardware components for industrial image processing. Be it in factory automation, the printing industry, for the food and beverage industry, pharmaceutical or logistics industry. IMAGO supplies vision systems, smart cameras, vision sensors and the appropriate software for the optimized use of our products. We pay special attention to miniaturization, high frame rates, increasing computing power and environmentally friendly power consumption. These characteristics already distinguish our products today.

***And we are proud of them.***