



Manual

VisionDevice – **Industrial DashCam**

Version 1.9 – April 2026

Contents

1	Handling and Safety Instructions	4
2	Introduction.....	5
2.1	Main features	6
3	Operating Conditions	7
4	Interfaces.....	8
4.1	Power and I/O	8
4.1.1	Digital I/Os	9
4.2	1 Gbit/s Ethernet M12	10
4.3	Status LEDs.....	11
5	Adjusting the Focus (S-Mount).....	12
6	Mechanical Drawings.....	14
6.1	S-Mount	14
6.2	C-Mount.....	15
7	Web Based Graphical User Interface (WebGUI).....	16
7.1	Overview.....	16
7.2	Accessing the GUI	16
7.3	Live View Page.....	17
7.3.1	Indicator Bar.....	19
7.4	Administrator Login Dialog.....	20
7.5	Setup Camera Dialog.....	21
7.6	IDC Configuration Dialog	23
7.6.1	Event Area Dialog	24
7.7	Advanced Configuration Dialog	25
7.7.1	General Tab	25
7.7.2	Camera Tab	28
7.7.3	Image Processing Tab	32
7.7.4	I/O Tab	33
7.7.5	Industrial DashCam Tab	35
7.8	View Video Dialog.....	36
7.8.1	Video Player Dialog.....	36

7.8.2	Frame Player Dialog	37
7.9	About Dialog	38
8	OPC UA Interface	39
8.1	Method Nodes	39
8.2	Data Nodes.....	40
8.3	Image Nodes	43
9	API	44
9.1	REST API.....	44
9.2	OpenAPI.....	44
10	Support	45
11	History	46

1 Handling and Safety Instructions



Depending on the operating conditions, the housing temperature can exceed 60 °C. There is a risk of injury!



EMC conformity according to EN/IEC 61000-6-2:2005 is qualified for cable lengths ≤ 30 m.



Electrical installation should be executed without power applied to the device and all connected devices.



Please take special note of the voltage range which may be applied to the device. Otherwise, permanent damage to the device may result!



Due to the characteristics and physical principles inside flash memory, **memory cards have a finite lifetime** dictated by the number of write operations. Therefore, take care of the regular write operations to prevent an early flash damage.

2 Introduction

Even in perfect machines, unwanted situations occur from time to time, which lead to machine downtime and thus to loss of production. It is crucial to know what exactly caused the downtime in order to avoid the sequence of events next time. Observing a working machine with the naked eye often does not yield much information due to the machine's high speed. Moreover, sometimes it is impossible or even dangerous. For such cases IMAGO has developed the VisionDevice – **Industrial DashCam** (VD-IDC).

The **Industrial DashCam** is a surveillance and remote monitoring camera for industrial environments in a match box form factor. The concept is similar to a dashboard camera, adapted for industrial environments. **Industrial DashCam** continuously monitors a scene without storing anything. Upon an event, which can be defined by the user, the **Industrial DashCam** saves the video on to local storage media. The length of the video as well as its span in time before and after the event can be defined by user. There are three types of possible events: it can be a hardware trigger, absence of a heartbeat or changes in image. The **Industrial DashCam** offers two digital inputs for the events.

This document is the manual of the **Industrial DashCam**. Hardware related aspects as well as the WebGUI operation are described.

2.1 Main features

- 21 – 28 V DC power supply
- Passive cooling without heat sink
- Image sensors:
 - 1920 × 1080 pixels
 - Global shutter
 - Monochrome or color
- Lens:
 - S-Mount or C-Mount
- Internal LED lighting:
 - Controllable via software
 - Automatic current regulation
- Recording:
 - Web-GUI available via the IP-address of the device
 - File Format: MPEG4 (H.264)
 - Frame rate: FULL-HD: ≈ 60 fps (mono)
 VGA: ≈ 180 fps (mono)
 QVGA: ≈ 370 fps (mono)
 - Recording time: ≤ 90 s (past, future, or a mix of both)
 - Mass storage ≥ 32 GB
 - Trigger Modes:
 - Regular: Video is recorded when the digital input signal raises
 - Heartbeat: Video is recorded when the Heartbeat signal is lost
 - Software: Recording is started after a threshold of change is reached within a ROI
 - Recording modes:
 - History: Video prior to the trigger event is saved
 - Future: Video after the trigger event is saved
 - Mixed: Video prior and after the trigger event is saved
- Digital inputs / outputs:
 - 4× digital output
 - 2× digital input
- Ethernet interface 1000 Mbit/s
- Housing:
 - 21 - 28 V_{DC} power supply
 - Passive cooling without heat sink

3 Operating Conditions

Power Supply:

Parameter	Min.	Typ.	Max.	Unit
Supply voltage	21	24	28	V
Supply current (@24 V)			0.5	A

Digital Input:

Parameter	Min.	Typ.	Max.	Unit
Input voltage range	0		25	V
Rising edge threshold voltage	7.4		9.4	V
Falling edge threshold voltage	4.7		6.3	V
Input resistance		15.5		kΩ

Digital Output:

Parameter	Min.	Typ.	Max.	Unit
Output current			50	mA
Output high voltage		$V_{\text{Supply}} - 0.2$		V

Environment:

Parameter	Value	Unit
Weight, without lens, tube, and cable	125	g
Operating temperature	5 ... 45	°C
Operating humidity, relative, non-condensing	5 ... 95	%
Storage temperature	-30 ... +70	°C
Storage humidity, relative, non-condensing	5 ... 95	%

4 Interfaces

4.1 Power and I/O

A non-shielded, 0.5 meter cable with an M12 8-pin connector is used for power supply and I/O signals.

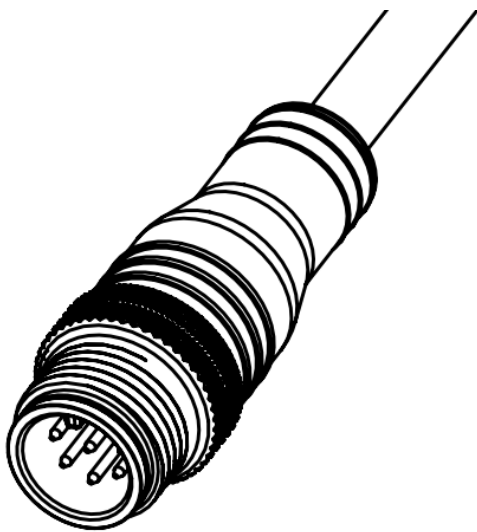

Figure 1: Power supply and I/O cable

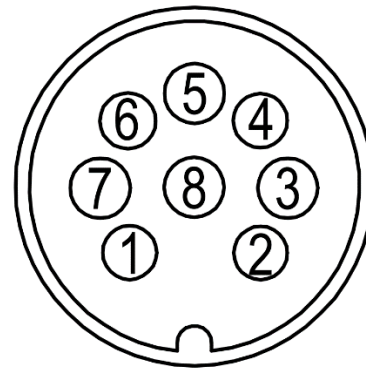

Figure 2: Pin assignment M12 connector

Pin	Function
1	Power (21 V-28 V)
2	GND
3	Digital IN0
4	Digital IN1
5	Digital OUT3
6	Digital OUT0
7	Digital OUT1
8	Digital OUT2

Table 1: Pin assignment M12 connector

4.1.1 Digital I/Os

The following illustration shows the electrical equivalent circuit for the digital input and output signals:

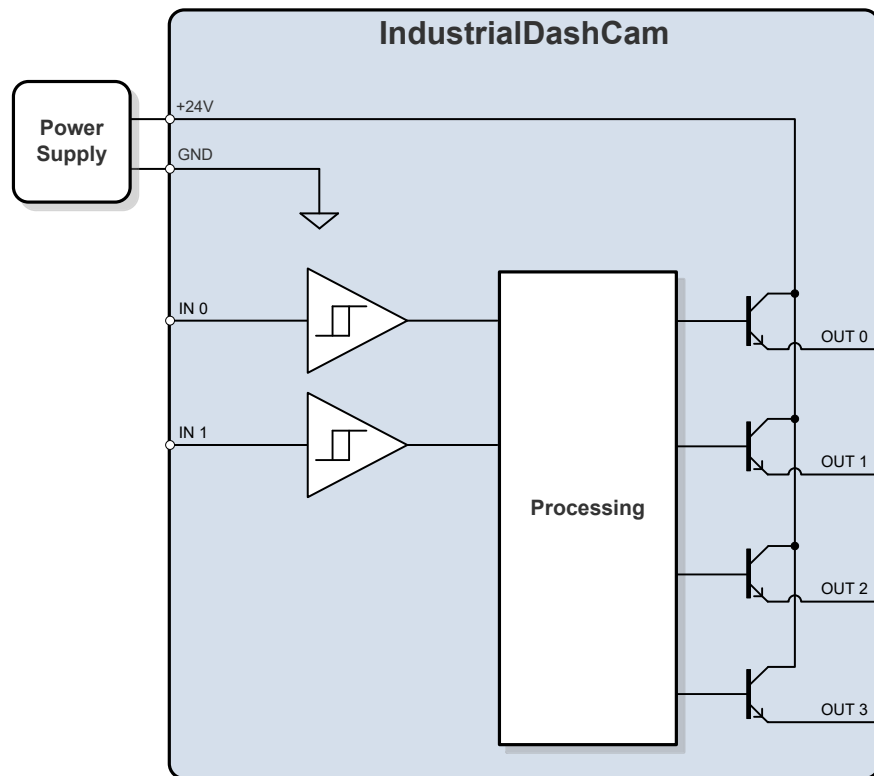

Figure 3: Simplified digital I/O circuit

The input signals use a Schmitt trigger circuit with the power supply GND as voltage reference.

The digital output circuit uses an open-emitter configuration. All outputs are internally supplied by the 24V power input.

4.2 1 Gbit/s Ethernet M12

A shielded 0.5 m Ethernet cable with a M12 8-pin X-coded connector is used for network communication.

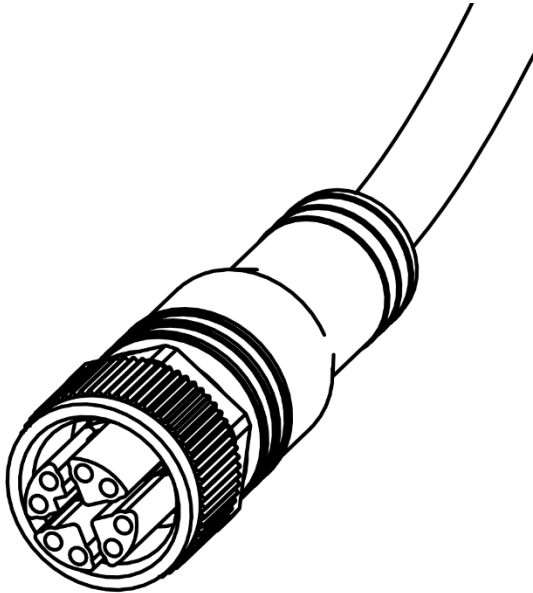

Figure 4: Ethernet cable

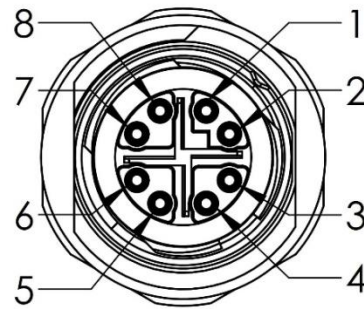

Figure 5: Pin assignment M12 connector

PIN	Function
1	D1+
2	D1-
3	D2+
4	D2-
5	D4+
6	D4-
7	D3-
8	D3+

Table 2: Pin assignment M12 connector

We recommend using shielded cables, for example:

Length	Product	IMAGO order code
1 m	Phoenix contact 1407471 "NBC-MSX/ 1,0-94F/R4AC SCO"	10007049
2 m	Phoenix contact 1407472 "NBC-MSX/ 2,0-94F/R4AC SCO"	10007050
5 m	Phoenix contact 1407473 "NBC-MSX/ 5,0-94F/R4AC SCO"	10008076

4.3 Status LEDs

The device is equipped with two status LEDs, namely “ETH” and “PWR”. The meaning of each status LED and its color is listed in the tables below.

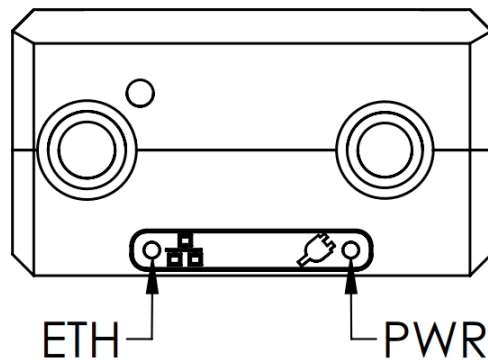

Figure 6: VisionDevice status LEDs

PWR LED	State
Green	Power on
Red	Digital IN0 signal active

Table 3: PWR LED states

ETH LED	State
Green	Ethernet link is up
Red	Ethernet activity

Table 4: ETH LED states

5 Adjusting the Focus (S-Mount)

To adjust the focus, you must first remove the hexagon socket set screw located on the back of the camera.

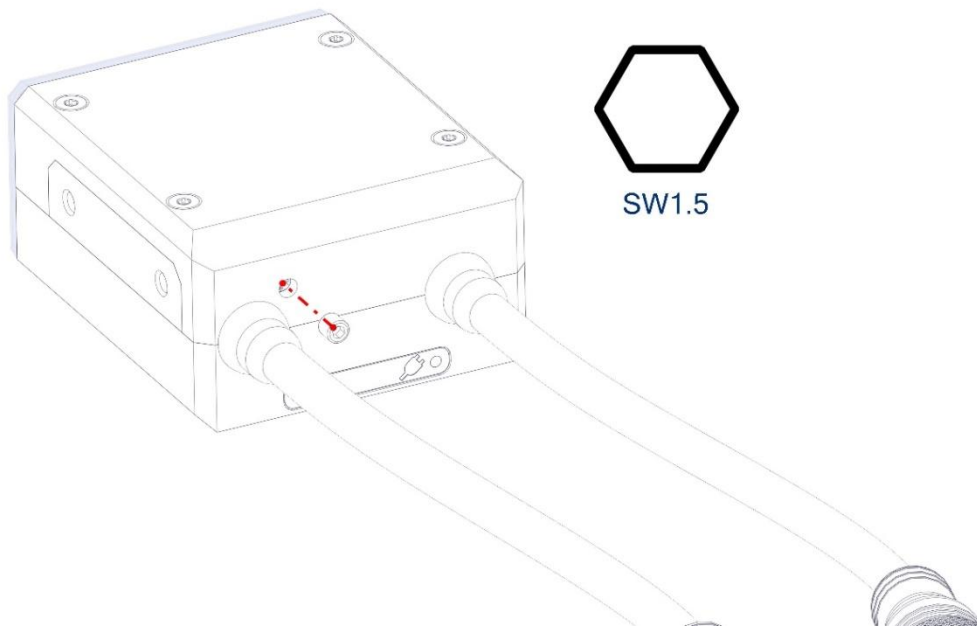

Figure 7: Removing the hexagon socket set screw

If you screw clockwise, the focusing plane will get closer to the camera.

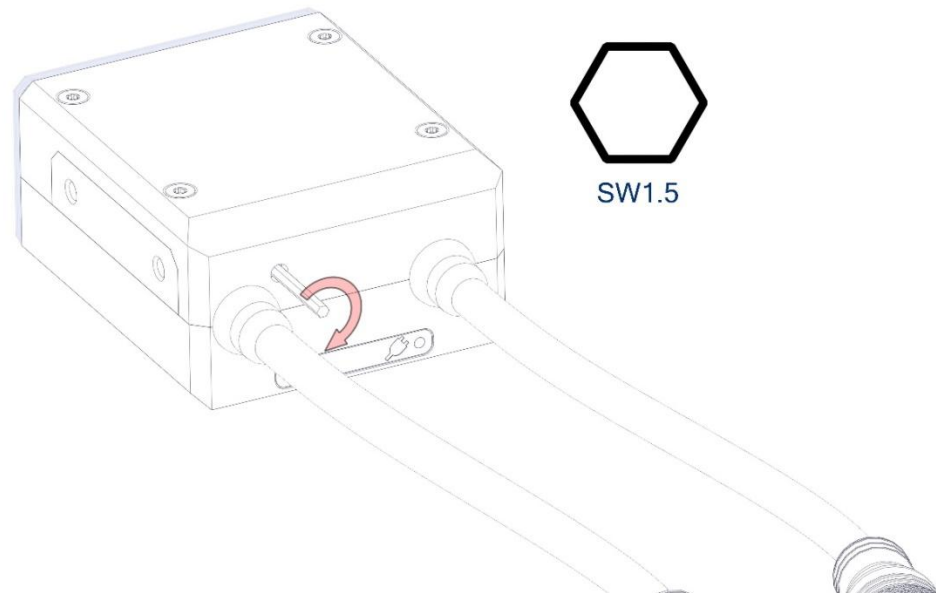

Figure 8: Adjusting the focus

If you screw counterclockwise, the focusing plane will get more distant.

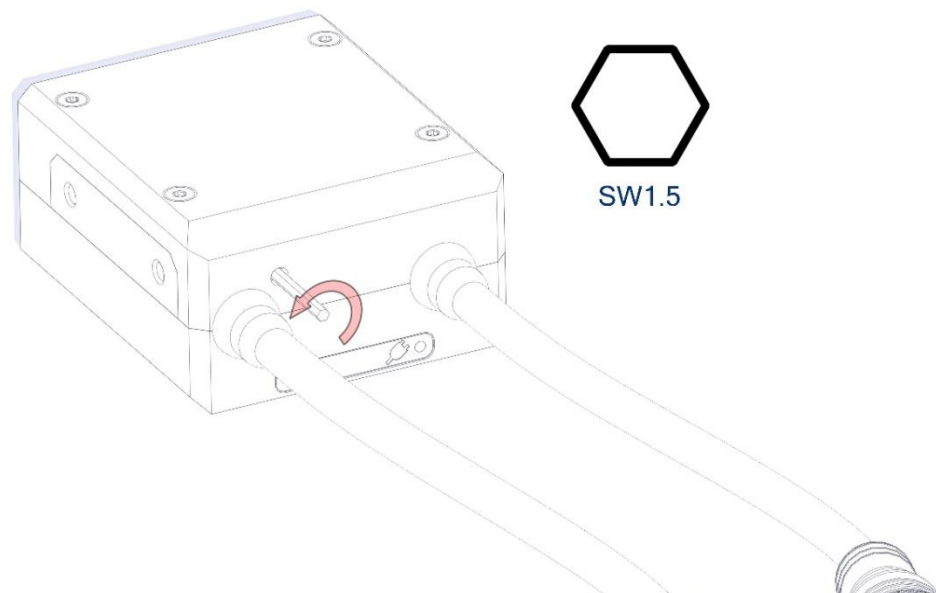
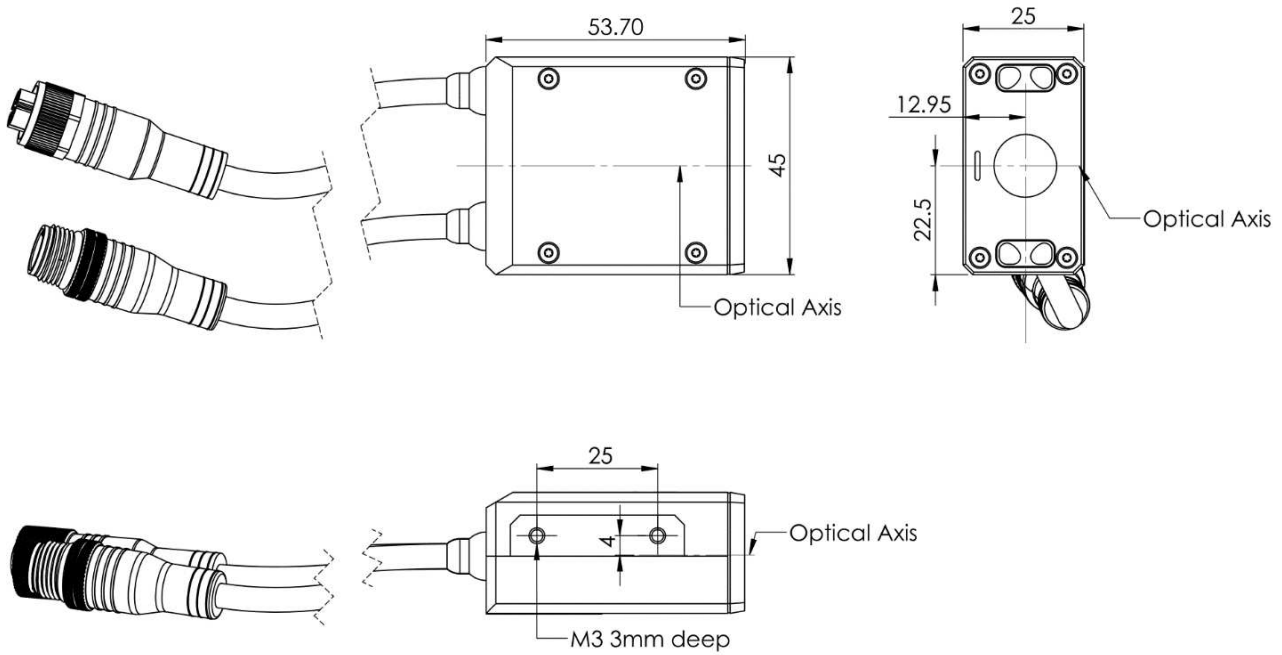

Figure 9: Adjusting the focus

6 Mechanical Drawings

6.1 S-Mount



6.2 C-Mount

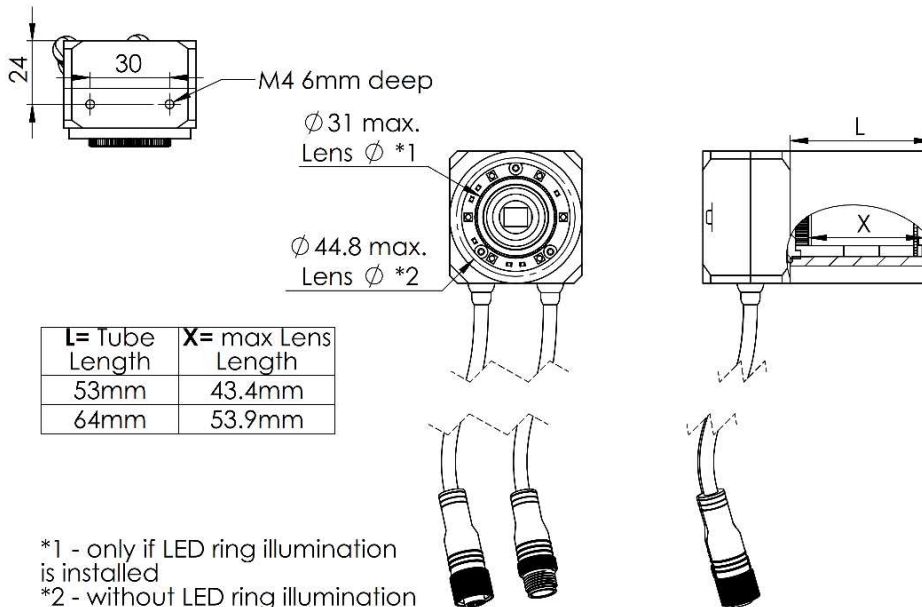
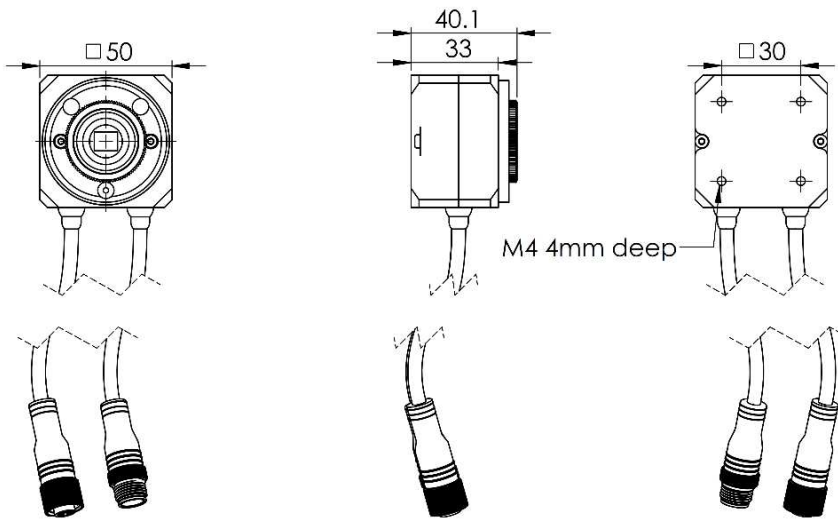
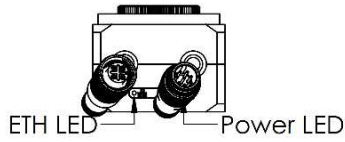

7 Web Based Graphical User Interface (WebGUI)

7.1 Overview

In this chapter the operation of the **Industrial DashCam** by means of the WebGUI is described. The GUI is a Web-based GUI, namely, it runs in an Internet-browser, for instance, Firefox, Microsoft Edge and so on. Thus, it is platform and operation system independent. WebGUI is operational as long as modern browser is supported.

The WebGUI has been designed with universality as the basis idea combined with the minimalism concepts. Under “universality” the authors mean the possibility to use the interface in a laboratory where low level features and settings must be available and in a production line, where the functionality must be reduced to bare minimum. In addition to that, the “universality” refers to the possibility of using the interface on devices, which do and do not support touch input.

The **Industrial DashCam** operation is independent from the WebGUI, namely the VD-IDC keeps operating even if the WebGUI is closed.

7.2 Accessing the GUI

The GUI is accessible from a browser running on a PC or a laptop. The PC or laptop must be connected to the same network (also logical, not only physical) as the **Industrial DashCam**. IP-address or the serial number of the **Industrial DashCam** is used for accessing the WebGUI. IP-address is entered into the address-line of the browser. Alternatively, the serial number can be used. The user should enter the serial number in the address line of the browser omitting the dashes and append “.local” to it. For example, assuming the serial number on the device is “VSPV-3003-100001”, the following should be entered into the browsers address line “VSPV3003100001.local”.





7.3 Live View Page

The Live View page is the first page shown to the user after opening the **Industrial DashCam's** WebGUI. It contains live image data from the camera and the *Indicator Bar* which is located on the bottom of the page and contains most used status information.





Figure 10: IDC Page

The title bar contains the following icons:

-  opens the **Event Log** window.
-  opens the **Administrator Login Dialog** (see 7.4)
-  switches between light and dark user interface theme.
-  shows the **Information Dialog** (see 7.9).

The camera image is located below the title bar. A green rectangle marks the current area of interest (AOI) that is grabbed by the camera. While image acquisition is running, the user can change the AOI by using the sliders below and to the right of the image.

Press the  **Set AOI** button to make the selected area take effect.

Use  **Maximize AOI** to restore the AOI size to the full camera image.

The  button near the slider controls restores the AOI to its previously used size.

A status line below the camera image displays the number of grabbed frames per second and the x and y coordinates when hovering over the image.

 **Scale** changes the magnification factor of the displayed camera image.

The action line at the bottom of the window has the following controls:

 **Start** enables the live visualization of the camera image.

 **Stop** disables live view.

 **IDC Event** generates a trigger event, and the video will be recorded according to the recording mode set by the user. While writing the video further trigger impulses are ignored.





 **Setup Camera** opens the Camera Setup dialog (see section 7.5).

 **Industrial DashCam** opens the configuration dialog for the IDC settings (see 7.6).

 opens the Advanced Configuration dialog that is only visible to users with administrator level (see section 7.7).

 **View Video** opens the Select Video dialog (see section 7.8).

There are two more controls at the right edge of the action line:

 changes between Free-Run () , Software () or hardware Triggered () camera modes.

An additional button  **Trigger** appears in software mode between the Start and Stop buttons. Pressing this button takes a single image.

 enables / disables the strobe of the camera (if available).

Setting a long exposure time might decrease the acquisition framerate, therefore please consider opening the aperture or bringing more light into the scene.

7.3.1 Indicator Bar

The **Indicator Bar** at the bottom of the window contains several indicators for the following information:

1. Small company symbol followed by copyright message
2. Name of the system (can be changed from the Configuration dialog)
3. Name of the active image processing procedure (Not used)
4. Name of the active communication procedure (Not used)
5. HTTP authentication indicator
6. User level indicator
7. Current state of the **Industrial DashCam**
8. OPC UA authentication indicator

The indicators are numbered in Figure 11, the numbers correspond to the list above. When placing a mouse cursor above an indicator a description of its function will appear in a pop-up bubble.

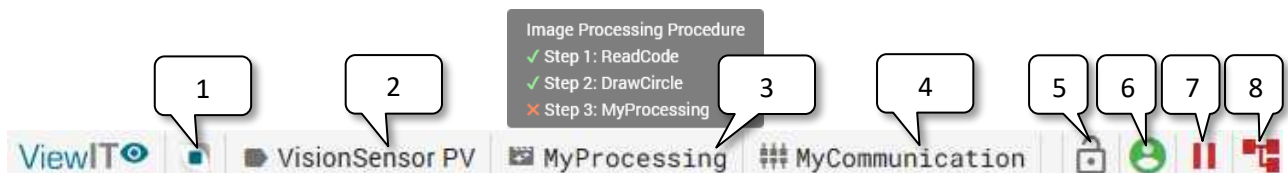

Figure 11: Indicator bar. The name of the Vision Device is VisionSensor PV, as indicated by 2.

7.4 Administrator Login Dialog

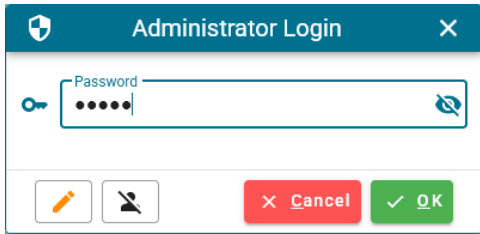







Figure 12: Administrator Login

The application starts with **normal** user level. A  symbol in the indicator bar signals this state. At this user level, changing of settings and writing of data is disabled. The corresponding items in the menu are greyed out. To use all functions, you need to switch to the **administrator** user level.



After pressing the icon  in the title bar, the **Administrator Login** dialog appears. Press  right of the input control to switch between hidden and visible password.

The default administrator password is admin.

The position of most dialog windows can be moved by dragging its title bar with the mouse. The mouse pointer changes to  while hovering the title bar. A double click on the title bar restores the position to the center of the browser window. A dialog is also closed by pressing the ESC key or the close icon (x) in the upper right corner of its title bar.

 **Cancel** closes the dialog.

 **OK** tries to log-in with the entered password.

If the correct password is used, the symbol in status bar changes from  to . If an incorrect password is entered, the application switches back to normal user mode.

When at administrator level, press the  button to go back to normal user mode.

There is a warning message if the default password is not changed. Pressing the  button expands the dialog to the **Change Password** dialog box. This button is only available when logged in as administrator.

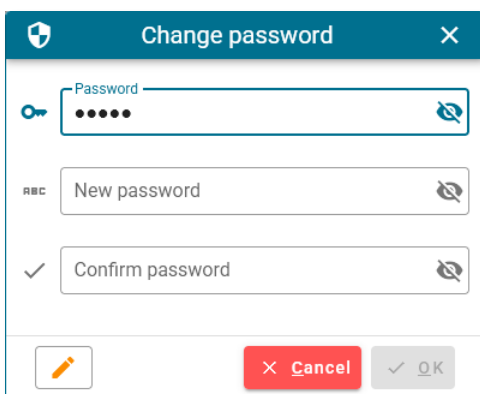

Figure 13: Change Password Dialog

To change the password, enter the currently active password and type a new password in the second input box. Confirm the new password in the third input box.

After setting the new password switch to the **Advanced Configuration Dialog** (see section 7.7) and save the settings permanently.

Do not forget the newly assigned password!

You can press  to switch back to the Login dialog.

7.5 Setup Camera Dialog

This dialog manages camera settings like exposure time, gain, white balancing, and strobe parameters. When this dialog is opened in **Live View** with active image acquisition all parameter changes are immediately applied to the live image.





 **Cancel** closes the dialog and rejects the changes.

 **Use** accepts the changes and closes the dialog.

 unfolds the following options:

 **Load** reloads the settings from flash memory reverting all changes.

 **Save** writes the current settings to flash memory.

 **Focus** performs an automatic search of the focus. The area for detection of image sharpness can be Full (whole image) () , Center (20 % of image width) () or Spot (10 %) () .
(Only available if an adjustable lens is mounted.)

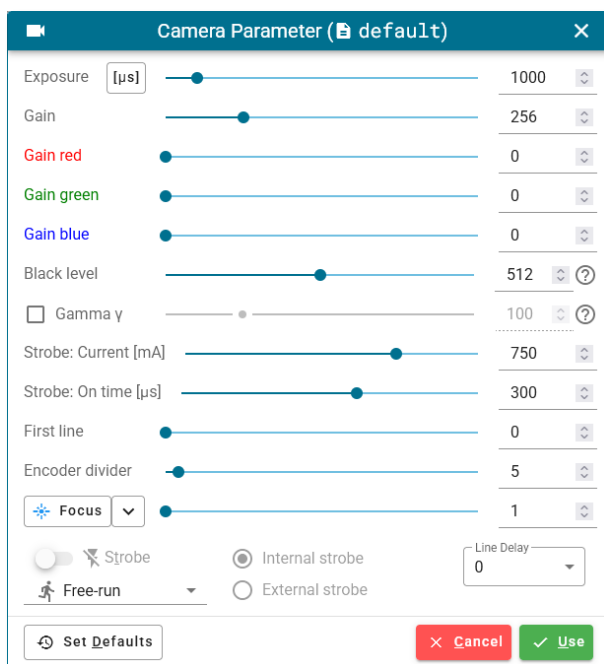

Figure 14: Camera Parameter Dialog

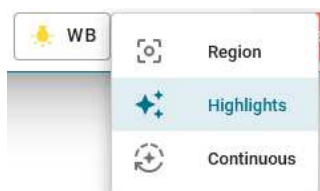

Figure 15: White Balance Options

When using a color camera while live view is active, the dialog box contains a button for **automatic white balance**.

The algorithm for performing the white balance starts from the current values of green, blue, and red and modifies them to achieve the same level for all three channels at certain pixels in the image. It takes a few frames to

determine the final values. The value for **green** serves as the basis for determining the values for red and blue. Therefore, it should be at 256 so that the other values can be within the available range.

Some parameters are only available for special camera types, e.g. Gain Red exists only for a color camera.

To better handle the wide range of exposure values, the user can switch between the units milliseconds **[ms]** and microseconds **[µs]**.

 **Set Defaults** sets the parameters to the sensor default values.

In **Region** mode, a region of 100 * 100 pixels in the center of the image is used to determine the current white value. In this mode, place a homogeneous gray object, such as a sheet of paper, in front of the camera. After pressing the WB button, the colors are adapted to this environment. When the lighting conditions change, you will need your “calibration object” again to repeat the adjustment. The process is finished after finding matching values. When closing the dialog, the automatic white balance process is interrupted, if it is still running.

In **Highlights** mode the brightest pixels (value from 200 to 240) in the whole image are used to calculate the color. These highlights can be, for example, reflections on metallic objects. In this mode, you do not need the “calibration object” and can perform the white adjustment with “natural” images. However, without the standardized object, the algorithm can find an incorrect white value depending on the scene in front of the camera. The algorithm will also fail if the scene is too dark and therefore has no highlights. This mode is also stopped after finding matching values or when the dialog is closed.

In **Continuous** mode, the adjustment of the gain values never stops, even when you close the setup dialog. So, you can use automatic white balancing in combination with the image processing. In this mode, the highlights are used because a static white object would interfere with image processing. New values are only determined after every 100 grabbed images in order to reduce the CPU load.

7.6 IDC Configuration Dialog

This dialog contains the user parameters that are associated with the video size and the trigger event.

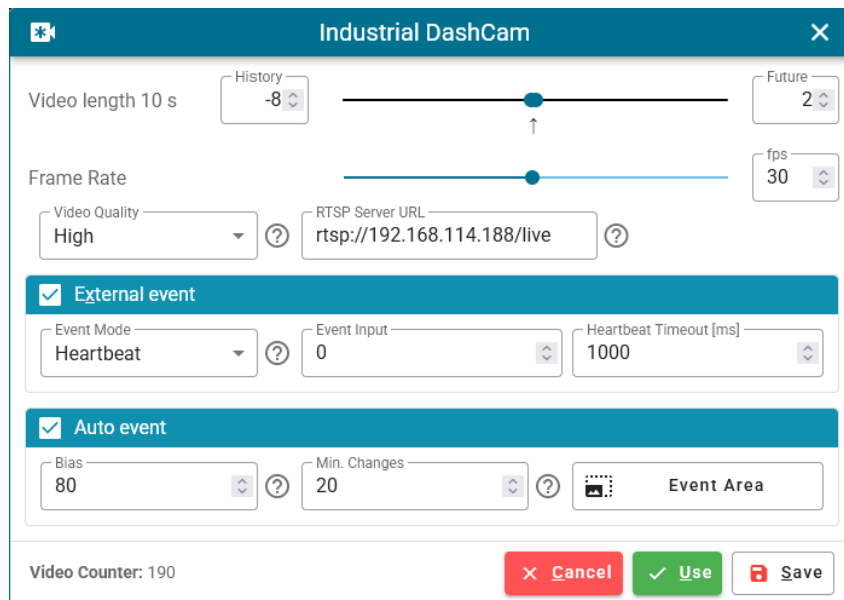

Figure 16: IDC Configuration Dialog

The length of a recorded video is set by the values History (time before the event) and Future (time after the event). Also, the range-slider can be used. The arrow in the middle \uparrow marks the point in time at which the event occurs. The left side represents the history part and the right the future part.

The distance between the two slider points is the resulting video length. Note that the video length is limited by the internal memory for capturing video frames and may not be shorter than 2 seconds.

The Frame Rate is limited by the capabilities of the camera sensor, such as the active region of interest and the selected exposure time. However, a lower value can of course also be chosen.

The Video Quality can be set to High, Medium and Low levels. A lower video quality reduces the size of the generated video files, while higher quality results in fewer compression artifacts.

Some encoder implementations support sending live videos via the Real-Time Streaming Protocol (RTSP). Use a tool like **VLC Media Player** to view the live stream from the RTSP Server URL.

When the External event group is activated, a video is written depending on the state of a digital input with the index Event Input. In Event Mode *Regular*, an event is created whenever a rising signal is received on the selected input line. In *Heartbeat* mode, the signal is used as a heartbeat with alternating rising and falling edges. A video is only saved if no signal change is detected for the specified time set by the value Heartbeat Timeout.

When enabling the Auto event group, an event is generated if there are too many differences between two consecutive images. The Bias parameter describes the sensitivity threshold for detecting changes between images. If the entire number of these detected differences exceeds the minimum number defined by the Min. Changes field, a video file is written. The value of this field is given as a percentage relative to the size of the event area.

Typical range values are:

- Bias: 30 – 150
- Min. Changes: 5 - 50%

 **Event Area** opens the dialog for setting the auto event trigger area. Do not confuse this area with the camera area! The triggering area must be within the area of interest of the camera. (See section 7.6.1).

 **Cancel** closes the dialog and rejects the changes.

 **Use** accepts the changes and closes the dialog.

 **Save** writes the current settings to flash memory. This button is only available for the administrator.

7.6.1 Event Area Dialog

This dialog allows you to define an area of interest for auto events. The shown image is no live image.



Figure 17: Event Area Dialog

The event region is defined by the white rectangle with green corners. A blue rectangle marks an active region of interest.



You can grab and drag each corner with the mouse. By pressing the mouse button inside the rectangle, you can move the area without changing its size. The mouse pointer will change its shape to indicate the mode.

Use the green range-sliders to adjust the size and the blue sliders to move the position.

 **Maximize** resets the area to the default maximum size.

 **Cancel** closes the dialog and rejects the changes.

 **Use** accepts the changes and closes the dialog.

Size () and coordinates of top left () and bottom right () corners are indicated.

7.7 Advanced Configuration Dialog

This dialog, which is only visible at the administrator level, contains settings for experienced users. The parameters are a selection from the Configuration dialog of the main page of the web interface. The dialog contains five tabs. The following buttons are available on each tab.

 **Cancel** closes the dialog and rejects the changes.

 **Use** accepts the changes and closes the dialog.

 **Save** writes the current settings to flash memory.

7.7.1 General Tab

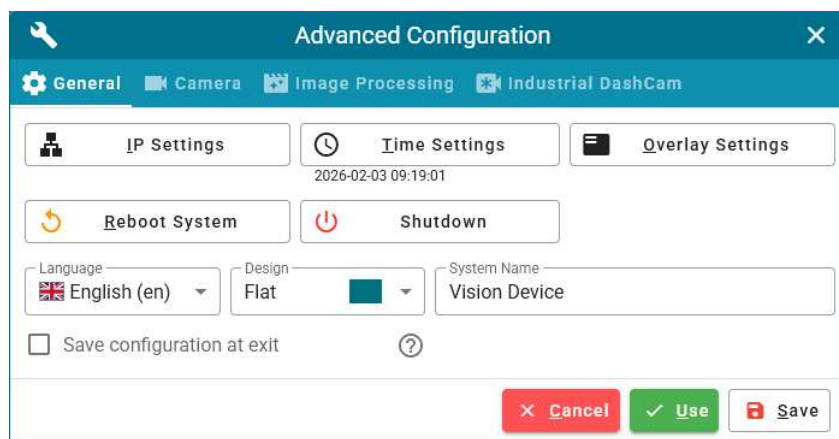



This tab contains common parameters that are relevant for the entire application.

Figure 18: General Tab

 **IP Settings** opens a new dialog for changing the current IP address of the device (see 7.7.1.1).

 **Time Settings** opens the time configuration dialog (see 7.7.1.2).

 **Overlay Settings** opens a dialog that handles drawing of processing data into the grabbed image (see 7.7.1.3).

 **Reboot System** quits the application and reboots the camera after confirmation.

 **Shutdown** will close the application and turn off the camera.

The application language can be changed via the select box **Language**, either *English* or *German*.

Use **Design** to change the appearance of title bars and buttons.



Flat design

Glossy design

The **System Name** is used as part of the filename of the created video files.

If **Save configuration at exit** is enabled, all configuration data and the event log are automatically saved when the application is terminated.

7.7.1.1 IP Settings Dialog

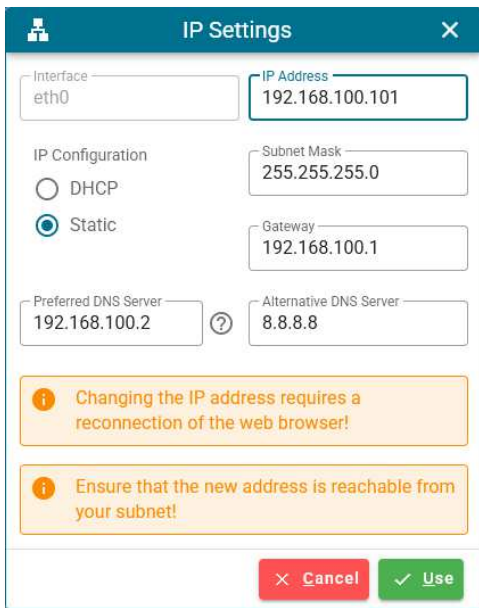

Figure 19: IP Settings Dialog

The user can switch between a static IP address and a dynamic address obtained by a DHCP server.

If the value Static for the IP Configuration is selected, a Subnet Mask and the addresses of the Gateway and DNS Servers can be entered. All addresses must be in a valid subnet.

Changing the IP address requires a reconnection of the web browser. Ensure that the new address is reachable from the subnet of the computer where the web browser is running.

7.7.1.2 Time Settings Dialog

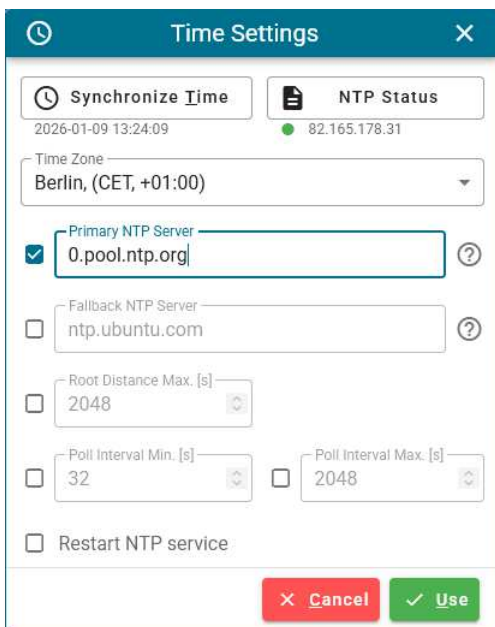

Figure 20: Time Settings Dialog

An NTP (Network Time Protocol) server distributes the time via the network to synchronize the time of other devices. By default, the Vision device synchronizes time via a pre-configured NTP server. This dialog allows the user to select a custom NTP server.

Synchronize Time sets the internal clock of the Vision Device to the time provided by the browser. The current time is shown below the button and is constantly updated.

NTP Status shows a report of the configuration. A green dot below the button indicates a valid connection to the NTP server.

In the Time Zone drop-down menu, you can select the desired time zone for the device. The list includes the most used time zones for convenience. Once selected, the device will automatically adjust its system time accordingly. Ensure the correct time zone is chosen to maintain accurate time synchronization.

Enter a single address or a list of addresses as the Primary NTP Server and optionally a list for the Fallback NTP Server, which will be used if the primary NTP servers are unreachable.

Use Root Distance Max to set the maximum clock offset to the time source.

The poll interval is the frequency at which the computer asks an NTP server for the time. You can enter the values for minimum (Poll Interval Min) and maximum (Poll Interval Max).

The Restart NTP service checkbox can be used if the service should be restarted without changing any settings. For the changes to take effect, no reboot is required. The device will immediately attempt to synchronize time with the newly configured NTP server.

7.7.1.3 Overlay Settings Dialog

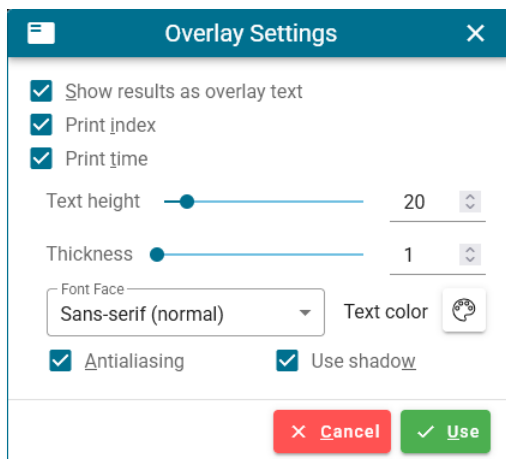

- **Show results as overlay**
Prints the results of the output parameters of the image processing into the grabbed image.
- **Print Index**
Prints the current image number in human readable form into the image.
- **Print Time**
Prints time stamp containing date and time like 2023-10-20 08:15:10,012 into the image.

Figure 21: Set Overlay Dialog

- **Text Height**
Size of text overlay
- **Thickness**
Line width of font
- **Font Face**
Font type
- **Text Color**
Press on the colored rectangle to open a color picker window.
- **Antialiasing**
Smooths edges of text.
- **Use Shadow**
Text is printed with a black shadow for better readability.

Cancel closes the dialog and rejects the changes.

Use accepts the changes and closes the dialog

7.7.2 Camera Tab

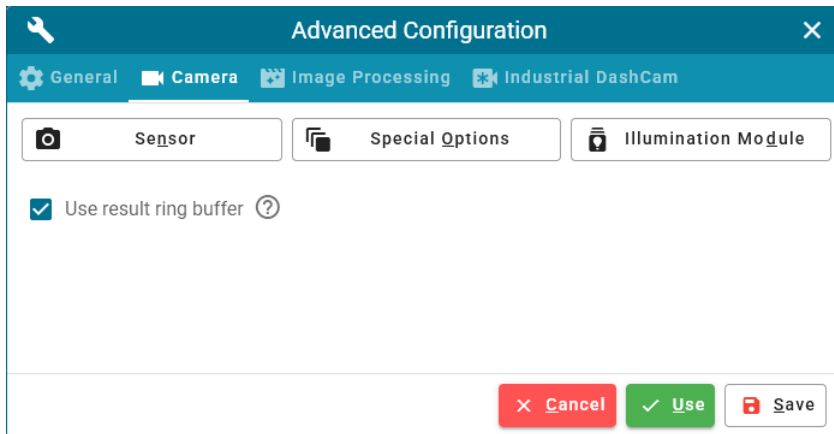

This tab contains some additional camera settings.

Figure 22: Camera Tab

 **Sensor** opens a dialog that allows a selection between physical and virtual sensor (see section 7.7.2.1).

 **Special Options** opens a dialog that contains sensor dependent settings like using a test pattern or flipping the acquired image (see section 7.7.2.2).

 **Illumination Module** opens a dialog that allows the configuration of a connected illumination unit (see section 7.7.2.3).

By default, the result images are stored into ring buffers for “good” and “bad”. You can disable this behavior with the option Use result ring buffer. This is suitable for reducing CPU load. A ring buffer for result images is not necessary in most cases when using the [Industrial DashCam](#).

7.7.2.1 Sensor Dialog

This dialog allows you to select the source of image acquisition from one of three available sources.

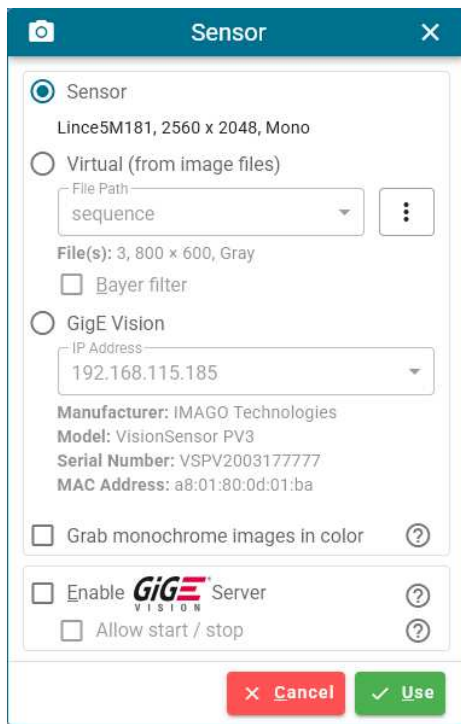



Figure 23: Sensor Dialog

- Sensor selects the physically present sensor. Name and properties are shown below.
- Virtual uses .BMP files in a directory as the data source. This allows the algorithms to be applied repeatedly to the same image data.

File Path sets this directory. The number of files and their image format is also displayed. The virtual camera may have a different resolution and even a different color format than the physical sensor.

This list box displays all folders in the directory /opt/ImagoTechnologies/ViewIT/images that contain a sequence of images.

 unfolds the following options:

 creates a new folder that will contain images.

 deletes the selected folder.

 opens the Manage folder dialog. This dialog will show all images files present in the folder. The user can view, delete, and upload files via drag and drop.

If a color sensor is using a Bayer pattern, images are nevertheless created in monochrome format. The algorithm cannot distinguish these images from true gray images. After enabling Bayer Filter these images are converted to color.

- GigE Vision allows grabbing images from another IMAGO device by using the GigE Vision protocol instead of the internal camera sensor.

After opening this dialog, the local network is scanned for valid camera devices, and their addresses are added to the list in the IP Address control. After selecting a device, information like manufacturer name and model type are shown.

If a monochrome sensor is installed, all images will be in an 8-bit gray format. Also, the overlaying marks created from the processing are drawn in gray. Enable Grab as color image to convert image data to RGB. This will increase CPU load and memory usage.

If Enable  Server is activated, all grabbed camera images are sent via the GigE Vision protocol. After connecting to this device, a client is able to grab preprocessed images and change the acquisition parameters. The client can be another instance of the Industrial DashCam using the GigE Vision interface or an application like HALCON HDevelop. This feature cannot be combined with GigE Vision input.

7.7.2.2 Special Options Dialog

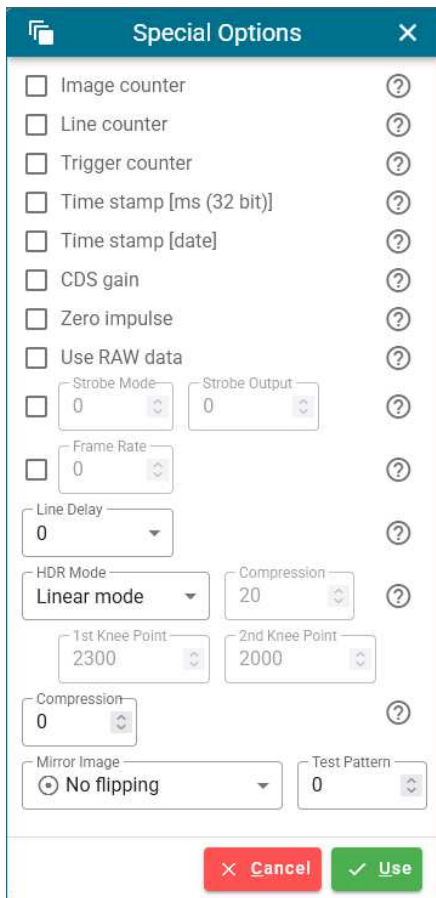

Figure 24: Special Options Dialog

This dialog contains sensor-specific features that are sometimes only available for a single sensor or hardware type. Therefore, the dialog will look slightly different for each hardware variant.

Image counter

Enables or disables insertion of a frame counter into the first pixels of a grabbed image.

Line counter

Inserts trigger and sensor readout counters at the beginning of each line.

Trigger counter

Enables or disables insertion of a trigger counter into grabbed image.

Time stamp

Inserts the grabbed time as 32-bit value into the image.

CDS gain

Enables analog gain value for the CDS pixel stage for a “Dragster” line scan sensor.

Zero impulse

Uses zero impulse from encoder for image start of a line sensor.

Use RAW data

Enabling this feature ignores the Bayer filtering of the sensor and returns only monochrome data.

Time stamp [date]

Enables or disables insertion of a time stamp into grabbed image. The first pixels of the image are set to values given in the table on the right side.

For the year 2023 the first pixel will have a gray value of 7, the second pixel 231 ($7 * 256 + 231$).

Pixels	Meaning	Range
YY	Year	1900 ... 2100
M	Month	1 ... 12
D	Day	1 ... 31
H	Hour	0 ... 23
M	Minute	0 ... 59
S	Second	0 ... 59
mm	Millisecond	0 ... 999
uu	Microsecond	0 ... 999
ttttttt	Timestamp	Microseconds

Strobe Mode

Sets the operating mode of the integrated LED unit and the exposure output signal.

Mode	Integrated LED	Digital Output OUT
0	Enabled	Controlled by digital output
1	Off	Sensor exposure signal
2	Off	Controlled by digital output
3	Enabled	Sensor exposure signal

Frame Rate

This feature limits the sensor frame rate in free run mode to the desired value in Hertz. The actual frame rate may be lower if the exposure time setting is too high, or if the sensor's limit is exceeded. The lowest achievable frame rate is 16 Hz for line scan mode, else 2 Hz.

Line Delay

For dual line sensors only.

This feature selects the readout delay for one of the sensor lines of a dual line sensor. This setting is used to compensate for the physical displacement of both lines depending on the transport direction used in the application.

HDR Mode

For Lince 5M181 sensor only.

In HDR mode, the pixel response is based on a piecewise linear compression curve. A light intensity range of up to 100 dB is mapped to 8-bit output values.

The following parameters control the response curve:

- Number of knee points, (1 ... 2)
- Compression factor (1 ... 500)
- Position of the first knee point (1.8 ... 3.0)
- Position of the second knee point (1.8 ... 3.0)

See https://api.imago.tech/FGCamera/_lince5_m181.html for more information.

Compression

For Sony IMX565 / IMX567 sensors only.

A linear mapping of 10-bit pixel values to 8-bit output values is used by default. Activating compression allows for higher resolution in low light and lower resolution in bright light.

See https://api.imago.tech/FGCamera/_i_m_x56x.html for more information.

Mirror Image

This feature can flip the image horizontally, vertically or in both directions.

Test Pattern

It activates a sensor internal pattern. The count and style of patterns depend on the type of sensor.

✖ Cancel closes the dialog and rejects the changes.

✔ Use accepts the changes and closes the dialog.

7.7.2.3 Universal Illumination Module

If a **Universal Illumination Module** is connected, the sensor can grab a sequence of up to four subsequent frames, each with different illumination settings.

✖ Cancel closes the dialog and rejects the changes.

✔ Use accepts the changes and closes the dialog.

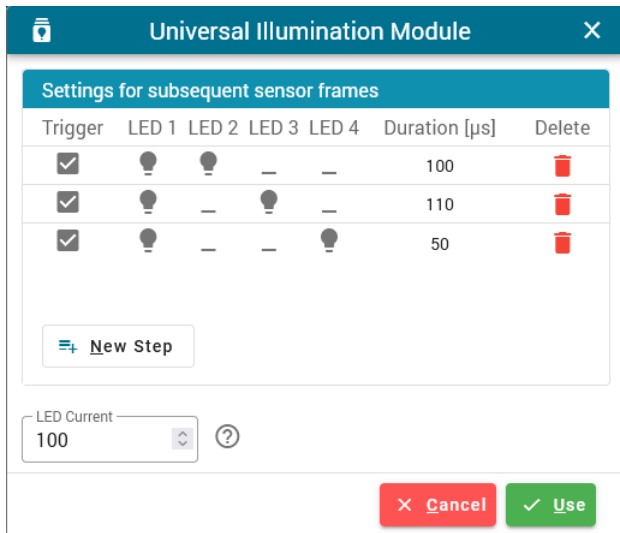

- **Trigger**
Trigger mode for the selected sequencer step. This setting is ignored in free run mode.
 - **Off**
Disable sensor trigger for this step and acquire image when the sensor is ready.
 - **On**
Enable sensor trigger for this step (default).
- **LED 1 ... LED 4**
Active illumination elements
- **Duration [µs]**
Length of time during which the LED units are switched on.
- Deletes the current step.

Figure 25: Universal Illumination Module Dialog

+ New Step creates a new line of settings. After the last step, the sequence starts again.

The value LED Current sets the current in percent for adjustable LED units.

7.7.3 Image Processing Tab

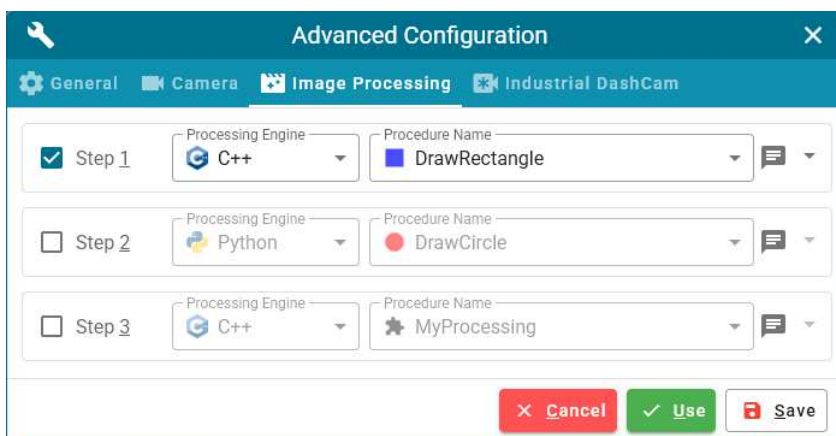



Figure 26: Image Process Tab

This tab allows the user to enable or disable each image processing step.

For each step, the type of the processing engine (C++, HALCON or Python) and the name of the selected procedure are shown. Hovering the  symbol shows the procedure's comments.

To change a procedure and its parameters the full version of [ViewIT](#) is necessary.

7.7.4 I/O Tab

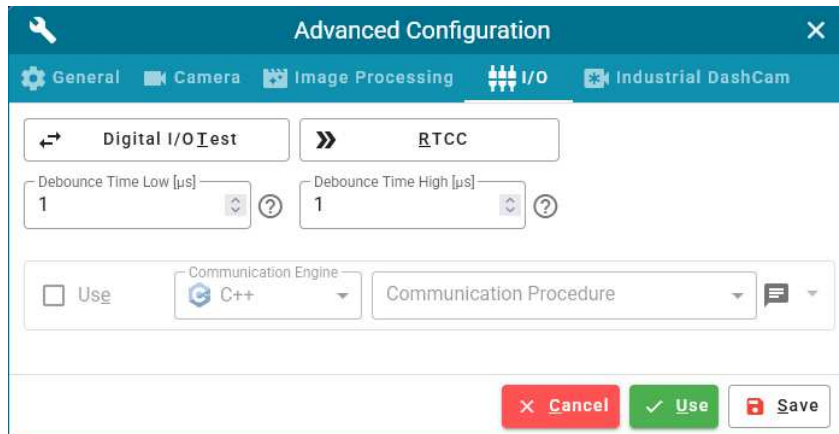

This tab provides settings for digital inputs and communication related parameters.

Figure 27: I/O Tab

↔ Digital I/O Test opens the **Digital I/O Test** dialog (see section 7.7.4.1).

» RTCC opens the **Real Time Communication Controller** dialog (see section 7.7.4.2).

Debounce Time Low / High sets debounce time for digital input signals in μs .

You can enable / disable a selected I/O procedure. To change the procedure and its parameters full version of ViewIT[®] is necessary.

7.7.4.1 Digital I/O Test Dialog

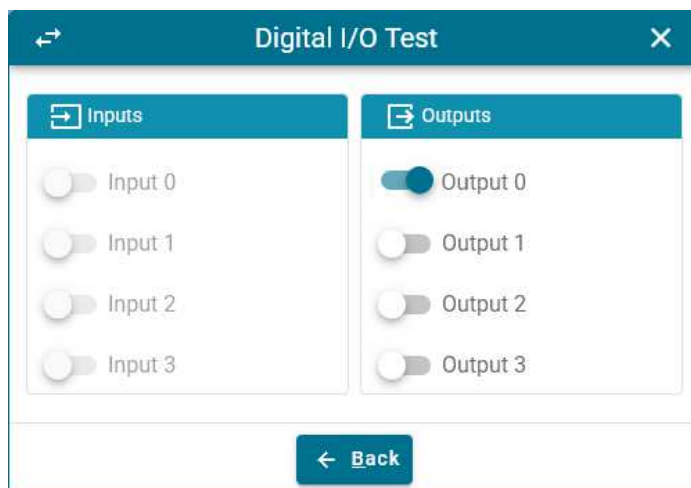

The current state of all available inputs is indicated on the left side. Use the switches to enable / disable any output.

← Back closes the dialog and disables all outputs.

The number of inputs and outputs depends on the hardware type and is detected automatically.

Figure 28: Digital I/O Test Dialog

7.7.4.2 RTCC Dialog

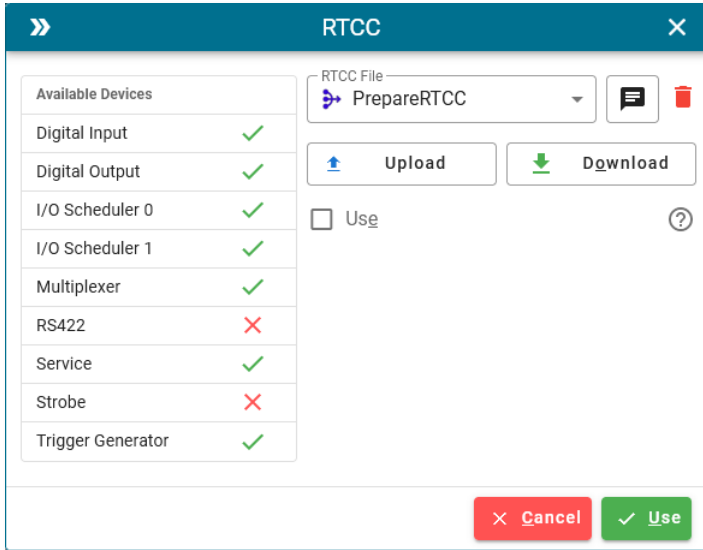





Figure 29: Digital I/O Test Dialog

The **Real Time Communication Controller** contains different devices like *Digital Inputs* or the *Trigger Generator*. The availability of a device depends on the hardware type.

A user can write a Python script to configure the devices. For example, a digital input can be connected via the *Multiplexer* to the *Trigger Generator* to change the state of a digital output at certain conditions.

The script file is selected from the RTCC File box. The  button shows information and the source code of the script, the  icon deletes the selected file.

Use the  **Upload** and  **Download** buttons to exchange scripts with the PC.

Enable **Use** to activate the script. It is called only one time at the start of the program or when a different script is selected.

This feature is reserved for **experienced users** who need exclusive access to the RTCC.

Unguarded use can prevent features like camera trigger from working!

 **Cancel** closes the dialog and rejects the changes.

 **Use** accepts the changes and closes the dialog

7.7.5 Industrial DashCam Tab

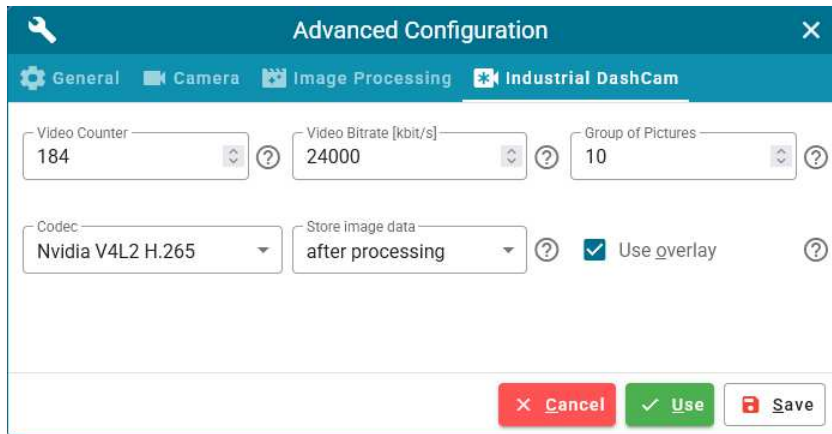

This tab contains additional settings for the IDC.

The name of a written video file contains a prefix number that is incremented after each save operation, as well as the time when the file was created. The user can change this number via the Video Counter input field.

Figure 30: Industrial DashCam Tab

A higher Video Bitrate leads to better video quality. When using a smaller region of interest or less frames per second, the bitrate can be reduced. A very good quality is achieved with 24 000 kbit/s for 1920 × 1080 and 60 fps.

An MPEG-4 video contains complete images (so-called intra-coded images) and predicted images, where only the differences to other frames are stored in order to reduce the file size. A Group of Pictures starts with an intra-coded full image as the anchor frame, followed by several difference images. Larger GoPs lead to better compression, smaller GoPs offer more precise seeking.

The video encoder hardware can support various standards for video compression, such as H.264 (Advanced Video Coding, AVC) or H.265 (High Efficiency Video Coding, HEVC). Use the Codec box to select one method.

Select *Store image data before processing* to store the unaltered image data captured directly from the camera before any image processing procedure is called. If the *after processing* option is selected, images that may have been altered during the processing steps will be written into the video.

If *Use overlay* is enabled, the time stamp and the system name are printed at the bottom of each grabbed image. For a more precise configuration of the overlay style, use the *Overlay Settings* on the *General* tab (see 7.7.1).

7.8 View Video Dialog

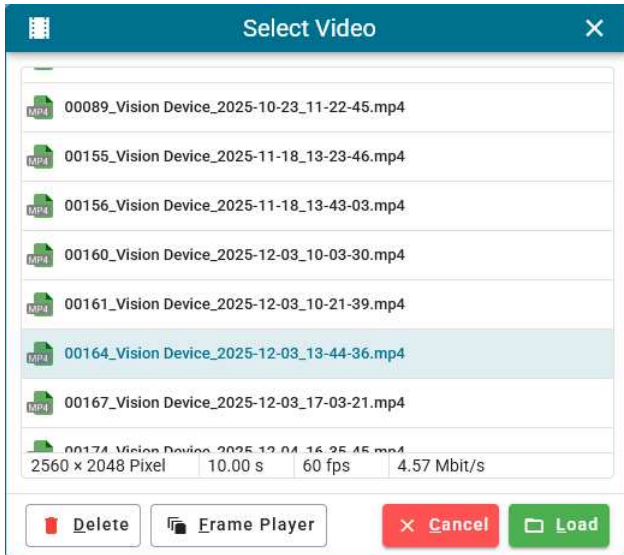

Figure 31: Select Video Dialog

The dialog is for viewing a previously written video file. You can select an existing video file from the list and then play it.

Cancel closes the dialog.

Load loads the video and opens the **Video Player Dialog** (see section 7.8.1). Double-clicking a selected video file also opens the video player.

Delete deletes the selected file after acknowledging.

Frame Player opens the **Frame Player Dialog** (see section 7.8.2).

When selecting a file, the image dimensions and some video statistics are displayed.

7.8.1 Video Player Dialog

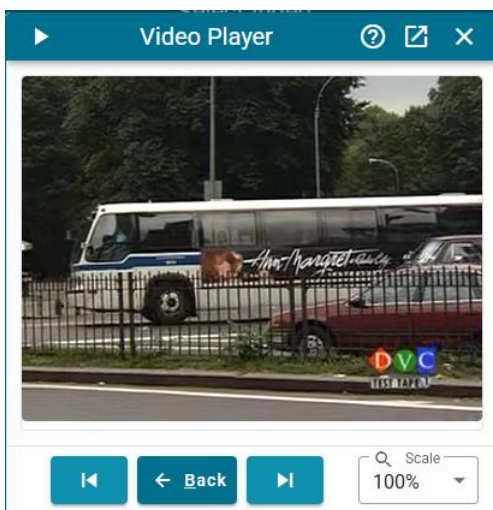

Figure 32: Video Player Dialog



This is the most simple and easiest way to view a recorded video. To play the video, the standard video control provided by the browser is used.

Back closes the dialog.

◀ opens the previous video file from the directory.

▶ opens the next video file from the directory.

Scale changes the magnification factor of the displayed video.

Hovering over the icon  in the title bar shows information such as image size and number of frames in the video file. The symbol  opens the video in a separate browser tab.

7.8.2 Frame Player Dialog

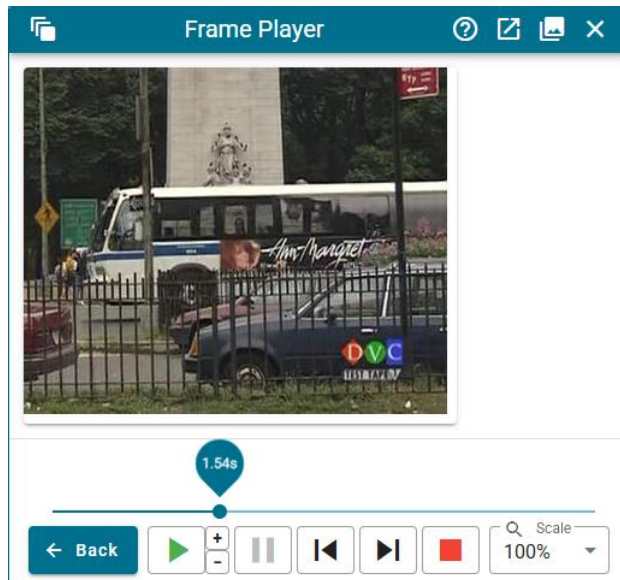

Figure 33: Frame Player Dialog

The Frame Player allows the user to view the video frame-by-frame. When the video is loading, it will take a while until the controls are available. While loading, press **Stop Loading** to break the conversion and work with the until then loaded images.

Use the slider to wind to a specified time point.

← Back closes the dialog.

▶ plays the video in a loop. **+** and **-** change the playback speed.

⏸ pauses the video when playing.

⏮ jumps to the previous frame.

⏭ jumps to the next frame.

■ stops the animation and jumps to the first frame.

🔍 Scale changes the magnification factor of the displayed video.

As in the Video Player Dialog, hovering over the icon **?** in the title bar shows information about the video file. The icon **🔗** opens the video in a separate browser tab, the icon **🖼** opens the current video frame in a browser tab.

7.9 About Dialog

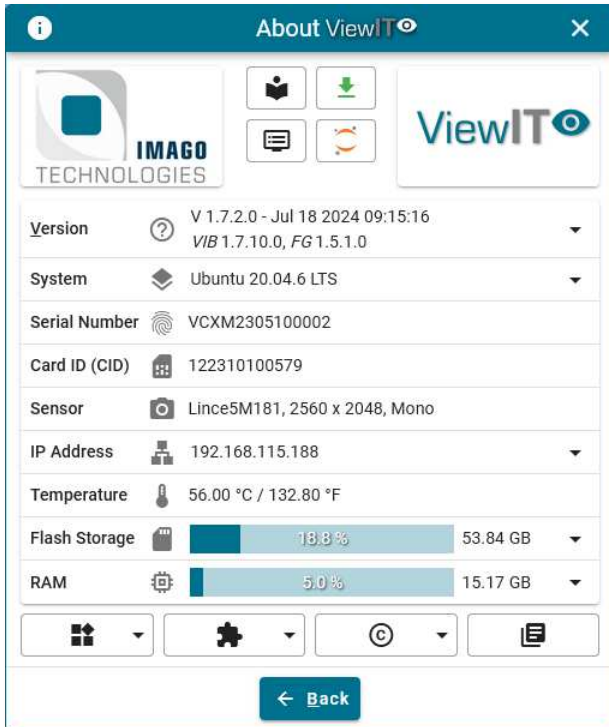















Figure 34: Information Dialog

This dialog shows information like program version, serial number of the device, operating system, available capacity of the flash card, etc.

-  opens a dialog window containing this documentation. The user can move the document to a new browser tab by pressing  in the title bar. Use  in the bottom left to switch between
 -  Manual,
 -  Plug-In API, the documentation on how to develop a plug-in,
 -  REST API, the interactive documentation of the REST API,
 -  IMAGO SDK documentation.
-  saves the full version of the information as a .json file.
-  opens a new browser tab that gives access to the **REST API** (see section 9.2).
-  opens a new browser tab and starts a JupyterLab server. (This feature is not available in all editions.)

 opens a list of program features.

 opens a list of used components and their version numbers.

 opens a list with copyright information for the used components.

 shows the change log.

 closes the dialog.

8 OPC UA Interface

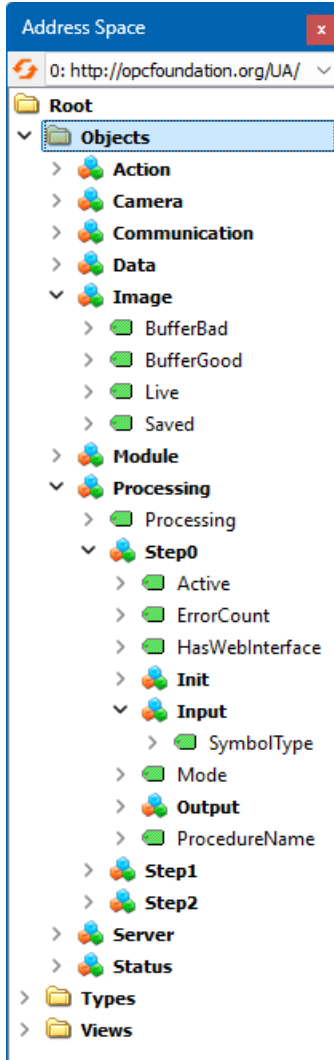

Figure 35: OPC UA Address Space Tree

Open Platform Communication Unified Architecture (OPC UA) is a machine-to-machine communication protocol. (<https://opcfoundation.org/about/what-is-opc/>).

All data in the address space is represented hierarchically in a structure of nodes and folders.

An OPC UA client can subscribe to elements in the address space and monitor changes to the data. The client can also write data based on access permissions.

You can test the interface with the free client **UaExpert** that is available via this link:

<https://www.unified-automation.com/downloads/opc-ua-clients.html>

The **Industrial DashCam** contains an OPC UA server that automatically creates an address space containing the folders Action, Camera, Communication, Data, Image, Module, Processing and Status. The folders Processing and Communication and their sub-folders are generated by the parameters of the active image processing and I/O procedures.

The OPC UA client can read all information from the tree. Some data in the folders Camera, Communication and Processing → Init / Input is also writable.

It is also possible to use an encrypted connection that uses a self-signed certificate with different security levels like Basic 256 SHA256 or AES128 SHA256 RSA-OAEP.

8.1 Method Nodes

The folder Action contains only method nodes. Methods define callable functions and are invoked using the Call service.

Node	Function
ClearStatistics	Resets the image counters.
DoTrigger	Sends a software trigger to start image acquisition.

8.2 Data Nodes

The folders Camera, Communication, Data, Module, Processing and Status contain parameter settings. Some nodes are read-only, but many can also be written by the user.

Folder	Node	R/W	Function	
Camera			Camera settings	
	AOI			Area of interest
		Bottom	✗	Bottom row
		Left	✗	Left column
		Right	✗	Right column
		Top	✗	Top row
	BlackLevel	✓	Black level offset (default: 512)	
	Current	✓	Strobe current in mA	
	Exposure	✓	Exposure value in μ s	
	Focus	✓	Sensor focus (Only valid if a liquid lens is attached.)	
	Gain	✓	Gain value	
	GainBlue	✓	Gain value (Blue channel)	
	GainGreen	✓	Gain value (Green channel)	
	GainRed	✓	Gain value (Red channel)	
	Gamma	✓	Gamma value (100 correspond to 1.0)	
	UseGamma	✓	Activates gamma setting	
	GrabAsColor	✓	Grab monochrome image as RGB	
	Grabbing	✓	Image acquisition is running	
	OnTime	✓	Strobe active time in μ s	
	Rectification			Image rectification
		Border	✗	Crop border
		File	✗	Name of rectification file
		Interpo	✗	Image interpolation
		Type	✗	1: OpenCV, 2: HALCON
		Use	✗	true: Rectification enabled
	UseRoi	✗	true: Rectification ROI enabled	
	SensorName	✗	Name of sensor	
Special Options			Special options	
			Values depend on sensor type	
TriggerMode	✓	Trigger mode (0: Hardware, 1: Software, 2: Free run)		
UseStrobe	✗	Strobe enabled		
Virtual	✗	Read images from files		
Communication			Communication settings	
	Communication	✓	Communication plug-in is enabled	
	Init			Initialization parameters
				Various values
	Post			Parameters for Post() function
				Various values
	Pre			Parameters for Pre() function
				Various values

Folder	Node	R/W	Function	
Data			Common settings	
	AppPackage	✗	Name of installation package	
	AppVersion	✗	Full version of application	
	DarkTheme	✓	true: use dark theme for web interface, false: use light theme	
	Directory			Directories for stored data
		Image	✗	Images
		Log	✗	Log files
		Result	✗	Results
		Rtcc	✗	Scripts for Real Time Communication Controller
	Video	✗	Video sequences	
	Glossy	✓	true: use glossy button style	
	Halcon			HALCON settings
		ImageByReference	✗	Image is transferred as reference to HALCON instead of creating a copy.
		Path	✗	Path for stored HALCON scripts
	UseDebugServer	✗	Debug server is enabled	
	Language	✗	Language of user interface, 1: German, 2: English	
	Overlay			Information drawn into result images
		Fill	✓	Fill HALCON regions.
		Histogram	✓	Draw histogram.
		Index	✓	Print index of current image.
		LineWidth	✓	Width of drawn lines
		PaintRegion	✓	Paint HALCON regions.
		Results	✓	Print results.
		TextHeight	✓	Height of a line of text
		Thickness	✓	Thickness of printed text
	Time	✓	Print time of image grabbing.	
	PrimaryColor	✗	Primary color of web interface as HEX value. (#aaabbbccc)	
	SystemName	✗	Given system name	
	UnmodifiedImages	✓	If true, images are stored without overlay in ring buffers.	
	WebInterfaceOpen	✗	Value indicating whether web interface is opened.	
	WebServicePort	✗	Port for web interface	
	IDC			Industrial DashCam settings
		Available	✗	IDC is available
Bitrate		✓	Encoder bitrate in kbit/s	
Enabled		✓	IDC is enabled	
Event				
Overlay		✓	Show overlay information.	
VideoCount		✓	Index of stored video	
VideoFutureTime		✓	End position from now of recorded video	
VideoHistoryTime	✓	Start position from now of recorded video		

Folder	Node	R/W	Function	
Module			Module settings	
	Camera		Camera settings	
		Available	✗	List of available settings files
		Current	✗	Name of selected settings
	Io		Communication settings	
		Available	✗	List of available settings files
		Current	✗	Name of selected settings
	OpcUa		OPC UA settings	
		Available	✗	List of available settings files
		Current	✗	Name of selected settings
	Pro- cessing		Image processing settings	
		Available	✗	List of available settings files
		Current	✗	Name of selected settings
	Recipe		Combination of all settings	
		Available	✗	List of available settings files
		Current	✗	Name of selected settings
	Processing			Image processing settings
		Processing	✓	Processing is enabled.
StepN				Processing step N (0 ... 2)
		Active	✓	Step is enabled.
		ErrorCount	✗	Number of errors while executing this step
		HasWebInter- face	✗	Procedure has a web interface.
		Mode	✗	HALCON, C++ or Python
		ProcedureName		Name of processing procedure
		Init		Initialization parameters
				Various values
		Input		Input parameters
				Various values
Output			Output parameters	
			Various values	

8.3 Image Nodes

OPC UA allows also images as data type for nodes. All images are transferred as a ByteString in JPEG format.

Folder	Node	Function
Image		Image data
	BufferBad	Image from ring buffer "Bad"
	Index	Index of buffer
	BufferGood	Image from ring buffer "Bad"
	Index	Index of buffer
	Live	Live image
	Scale	Scale of live image in %, 100 equals original image size
	Saved	Saved image
	Name	Name of selected image file
	Available	List of saved images

9 API

The **Industrial DashCam** can also be operated via interfaces that are managed by a different computer – like a remote control.

9.1 REST API

REST API means **RE**presentational **S**tate **T**ransfer **A**pplication **P**rogramming **I**nterface. This interface is based on the behavior of the world wide web (WWW) and is a basic approach for the communication between client and server. This implementation exchanges data by HTTP methods like GET and POST which mostly transfer their content in form of JSON (**J**ava**S**cript **O**bject **N**otation) messages.

The REST API is accessed by calling a specific URL (**U**niform **R**esource **L**ocator). The URL consists of a scheme, the host address, an optional port number and a path.

Example: <http://192.168.1.10:80/help>

[Scheme://Host:Port/Path](#)

IP address and port number can be changed in the General Tab of the Advanced Configuration Dialog (see section 7.7.1.1).

In this way, the resources of the **Industrial DashCam** application are usable from other applications. For example, a user program can call the image processing capabilities to integrate them smoothly into its own user interface. A REST API is a stateless process. Every transaction is an isolated action without information or references of previous actions.

9.2 OpenAPI

Machine-readable API descriptions are ubiquitous nowadays and *OpenAPI* is the most broadly adopted industry standard for describing new APIs. The **OpenAPI** Specification (OAS) allows the description of a remote API accessible through HTTP or HTTP-like protocols. The main advantage of an API description file over documentation which only humans can read is that it enables automated processing.

OpenAPI descriptions are written as a text document that represents a JSON object, in either JSON or YAML format.

The interactive documentation for the REST API is in OpenAPI format. It is available from the About dialog and contains more information about the several commands. The web page is accessible by http://ip/rest-api/rest_api.html.

10 Support

Finally, if you have any open questions, the IMAGO support team is happy to assist you in all cases. For direct contact to the support, please use our ticket system: <https://imago.freshdesk.com>

Also, visit our IMAGO Download Portal: <https://www.imago-technologies.com/support>

11 History

Revision	Date	Changes
1.0	Aug-04-2023	First release Based on IDC manual V 1.3
1.1	Sep-06-2023	Changed formatting
1.2	Nov-21-2023	
1.3	Feb-21-2024	Added image sensor information
1.4	Mar-01-2024	Added thermal considerations
1.5	Nov-06-2024	New features from IDC version 1.0.0.0
1.6	Feb-21-2025	New features from IDC version 1.0.1.0
1.9	Apr-02-2026	Merge with ViewIT ™