



Vision Sensor PV4

ULTRA COMPACT IMAGE PROCESSING COMPUTER

ULTRA COMPACT IMAGE PROCESSING COMPUTER

Vision Sensor PV4

The Vision Sensor PV4 is a compact, freely programmable smart camera featuring a multi-core ARM CPU and an integrated Neural Processing Unit (NPU) for on-device AI inference. Its modular sensor head enables flexible sensor configurations, while all image processing tasks—classical algorithms and AI models—run directly on the device without the need for an additional IPC. With its Linux-based architecture, the PV4 supports custom software environments and efficient execution of user-defined scripts, making it an ideal solution for advanced inspection tasks that require higher performance, low latency, and compact integration.

Key Features

- Ultra compact and powerful
- Sensor Trigger
- Digital I/Os: 2IN / 4 OUT
- 4 LEDs
- Integrated NPU with 2 TOPS (1GHz) and 1 MB SRAM



Processor

Type	Hexa Core Arm® Cortex-A55
Processor Clock	6 x 1.8 GHz
DDR RAM	4 GB DDR4
Mass Storage	1 x µSD Card ≥ 32 GB

Interfaces

Ethernet	2.5 Gbit/s
Digital In/Out	2 x Input / 4 x Output, 24V

Sensor

Optical Size	1/3.1"	1/1.8"	1/1.8"
Resolution	2048 x 1536 pixels	2472 x 2064 pixels	3840 x 2160 pixels
Pixel Size	2.25 µm	2.74 µm	2.00 µm
Framerate	125 fps	96 fps	60 fps
Partial Scan	yes	yes	yes
Color	mono / color	mono / color	mono / color

Lens Properties (Optional)

Lens Mount	S-Mount
Focal length	e.g. 3.6mm / 4 mm / 6 mm / 7.5 mm LiqLens / 9 mm / ...

LED Strobe

LED Color	White
Quantity	4 x High-Brightness
Pulse Duration	Synchronized with shutter

Mechanical / Electrical

Power Supply	21 VDC – 28 VDC
Dimension W x H x D	45 mm x 53.7 mm x 25.5 mm
Weight	125 g
Temperature Range	+ 5 to + 40 °C
Ethernet Cable	0.5 m, M12 8 pin
I/O & Power Cable	0.5 m, M12 8 pin
Certification	IP50, CE
Mounting	4 x M3

Documentation

SDK Documentation [Link](#)

Dimensional Drawing

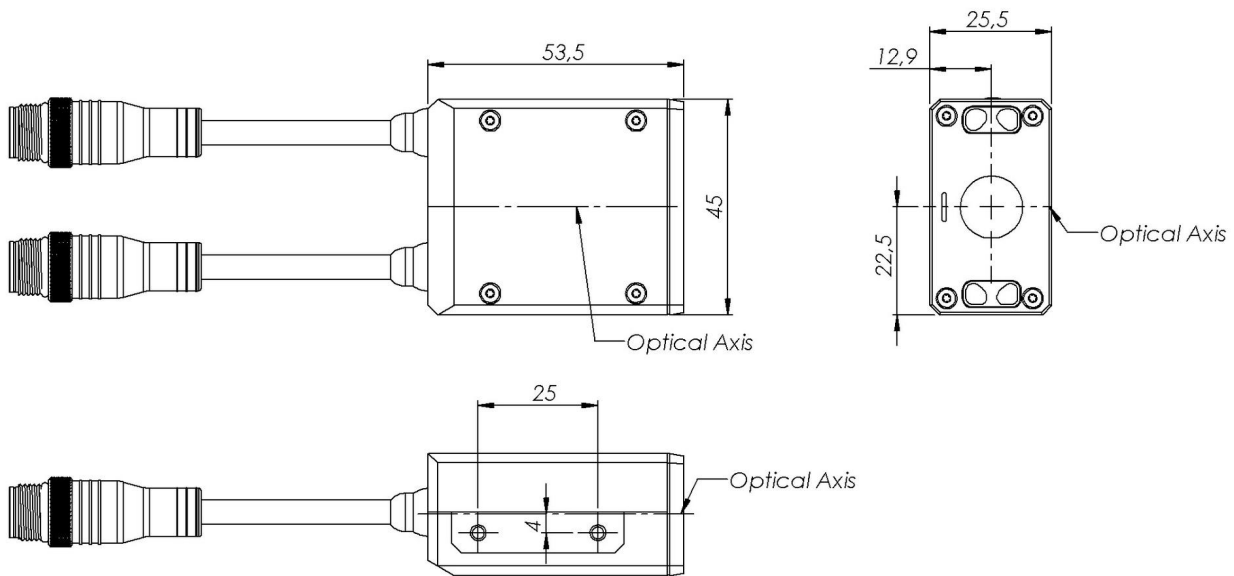

The smartest embedded vision components

For more than 30 years, IMAGO has been supplying machine vision technology to machine builders to improve product quality, make processes smoother, avoid production errors, reduce manufacturing costs and make systems more efficient.



What we do

With the focus on what counts for our customers, we develop hardware components for industrial image processing. Be it in factory automation, the printing industry, for the food and beverage industry, pharmaceutical or logistics industry. IMAGO supplies vision systems, smart cameras, vision sensors and the appropriate software for the optimized use of our products. We pay special attention to miniaturization, high frame rates, increasing computing power and environmentally friendly power consumption. These characteristics already distinguish our products today.

And we are proud of them.