



# Hardware Manual

## Vision Box Touch

Version 1-2 – 2026

## Contents

<b>1</b>	<b>Handling and Safety Instructions .....</b>	<b>3</b>
<b>2</b>	<b>Introduction.....</b>	<b>4</b>
2.1	<b>Key Features .....</b>	<b>5</b>
<b>3</b>	<b>Overview.....</b>	<b>6</b>
3.1	<b>Front-/Display-Side.....</b>	<b>6</b>
3.2	<b>Back-/VESA-Mount-Side .....</b>	<b>6</b>
3.3	<b>Position of Interface Connectors.....</b>	<b>7</b>
3.3.1	Right Side/ Mainboard Side/ Under the Heatsink.....	7
3.3.2	Left Side.....	7
3.4	<b>Basic features .....</b>	<b>8</b>
3.5	<b>Possible Configurations .....</b>	<b>9</b>
3.5.1	Dual Gbit, RTCC with 8× I/Os .....	9
3.5.2	Dual Gbit, RTCC with 8× I/Os, 4× RS232 .....	9
3.5.3	Dual Gbit, RTCC with 16× I/Os, 2× Strobe and Camera Trigger.....	9
3.6	<b>Block Diagram.....</b>	<b>10</b>
<b>4</b>	<b>Technical Data.....</b>	<b>11</b>
4.1	<b>Processors .....</b>	<b>11</b>
4.2	<b>Operating Conditions .....</b>	<b>12</b>
4.3	<b>Dimensions.....</b>	<b>14</b>
<b>5</b>	<b>Power Connector – Right Side.....</b>	<b>15</b>
<b>6</b>	<b>Interfaces.....</b>	<b>16</b>
6.1	<b>Ethernet Interface - Right Side (Single) .....</b>	<b>16</b>
6.2	<b>Ethernet Interface – Left Side (Dual) .....</b>	<b>16</b>
6.3	<b>DisplayPort Monitor Interface – Right Side .....</b>	<b>17</b>
6.4	<b>CFast – Right Side .....</b>	<b>17</b>
6.5	<b>Digital I/O – Left Side.....</b>	<b>18</b>
6.6	<b>LED Controller and Camera Trigger – Left Side .....</b>	<b>21</b>
6.6.1	LED Controller .....	21
6.6.2	Camera Trigger.....	22
<b>7</b>	<b>Accessories .....</b>	<b>23</b>
7.1	<b>Third-party Components.....</b>	<b>23</b>
7.2	<b>IMAGO Accessories .....</b>	<b>23</b>
<b>8</b>	<b>History .....</b>	<b>24</b>

## 1 Handling and Safety Instructions



Depending on the operating conditions, the housing temperature can exceed 60 °C. There is a risk of injury!



Handle with care! The housing, can have sharp edges. There is a risk of injury!



EMC conformity according to EN/IEC 61000-6-2:2005 is qualified for cable lengths ≤ 30 m.

Electrostatic discharge at unshielded I/O connectors can lead to unexpected events or data errors for the corresponding interface.



Electrical installation should be executed without power applied to the device and connected devices.



Before installing expansion cards, make sure that the Vision Box Touch is disconnected from power.

Use appropriate ESD protection when changing components.



### Only open if advised by IMAGO!

Warranty void if warranty seal is removed or broken.



Please take special note of the **voltage range** which may be applied to the device. Otherwise, permanent damage to the device may result!



### Air Circulation

Take care regarding air flow at the backside.



**Avoid extreme environmental conditions** and protect the Vision Box Touch from dust, humidity and heat.



Due to the characteristics and physical principles inside flash memory, **SSDs have a finite lifetime** dictated by the number of write operations.

Therefore, take care of the regular write operations to prevent an early SSD damage. Ask for the technical data of the used SSD and, if necessary, for support to calculate the lifetime.



Inform the user of the system that SSDs are wear parts which must be renewed regularly.

## 2 Introduction

Thank you very much for your interest in our Vision Box Touch. To get the most out of your purchase, please take some time to read all the information given here thoroughly.

This Vision Box Touch is optimized for cameras using the GigE Vision. For multi-camera systems, not only several camera ports but also several integrated LED Controllers and digital I/Os allow a compact setup without additional electronics. If you need more connectivity or a specific interfaces, kindly consult the other Vision Box Touch alternatives.

The integrated Real-Time Communication Controller ensures proper timing between all devices, even when using Windows or Linux operating systems. To avoid complex cabling, the cameras can be connected through standard Ethernet cables.

All components are available for several years in order to provide continuous delivery without changes. The AGE-X-SDK can be used in C++ and .NET as well as with some third-party machine vision libraries to enable an easy integration with your products and projects.

For series production, IMAGO delivers the VisionBox AGE-X inside the VisionBox Touch ready-to-run, including customer-specific SSD image, qualified 3<sup>rd</sup>-party components and acceptance test.

## 2.1 Key Features

The Vision Box Touch has integrated the mainboard of the Vision Box AGE-X5.1 and a 21.5" touch display into one compact housing. The key features are:

- Housing
  - IP65 housing design
  - Passive cooling
  - Interfaces behind the VESA 100 mount cover on the back.
  - 24 VDC power input
  - Sealed USB C on the front frame
  - The VESA 100 cover can be opened without unmounting the device from the display arm.
  - Display with narrow frame so the device stays compact.
- Display
  - 21.5", 1980×1080, option 1.280 x 720, 500cd/m<sup>2</sup>
  - Capacitive, 10 Fingers Multi-Touch
- 10<sup>th</sup> generation Intel Embedded x86 processor
  - Windows 10 IoT Enterprise LTSC 2021, optional Windows 11 IoT Enterprise
  - Debian GNU/Linux, optionally with *PREEMPT\_RT* patch
  - front panel
- Real-Time Communication Controller *RTCC*:
  - Controls vision- & automation-specific interfaces:
    - Digital I/Os
    - Camera trigger
    - LED Strobe Controller
  - Contains functional units for controlling I/Os in real time:
    - Trigger unit: Creation of trigger signals, derived from other inputs (e.g. encoder)
    - I/O scheduler: applies values stored in a FIFO to outputs in real time (based on trigger event, encoder position, or timer value)
    - Multiplexer: flexible connection of functional units
  - Operates independently from the OS & the x86 processor
  - Easy-to-use high-level API for C++, .NET and support by 3<sup>rd</sup>-party software tools
- Digital I/Os:
  - Opto-isolated
  - Status LEDs
  - Inputs up to 5 MHz with adjustable debouncing in *RTCC*. Communicated to x86 via interrupt or polling
  - Outputs up to 50 kHz / up to 1 A / up to 48 V
  - front panel
- More vision & automation interfaces
  - LED controllers up to 6 A strobe / 0,5 A continuous
  - Various interfaces behind the VESA 100 cover are possible.

### 3 Overview

#### 3.1 Front-/Display-Side

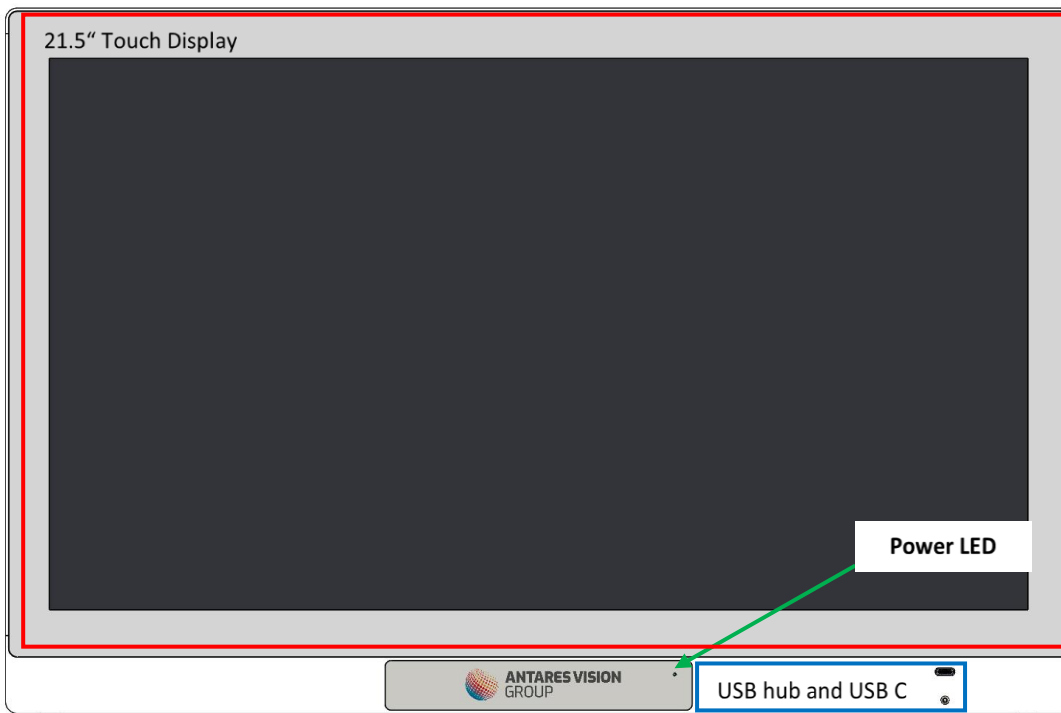

#### 3.2 Back-/VESA-Mount-Side

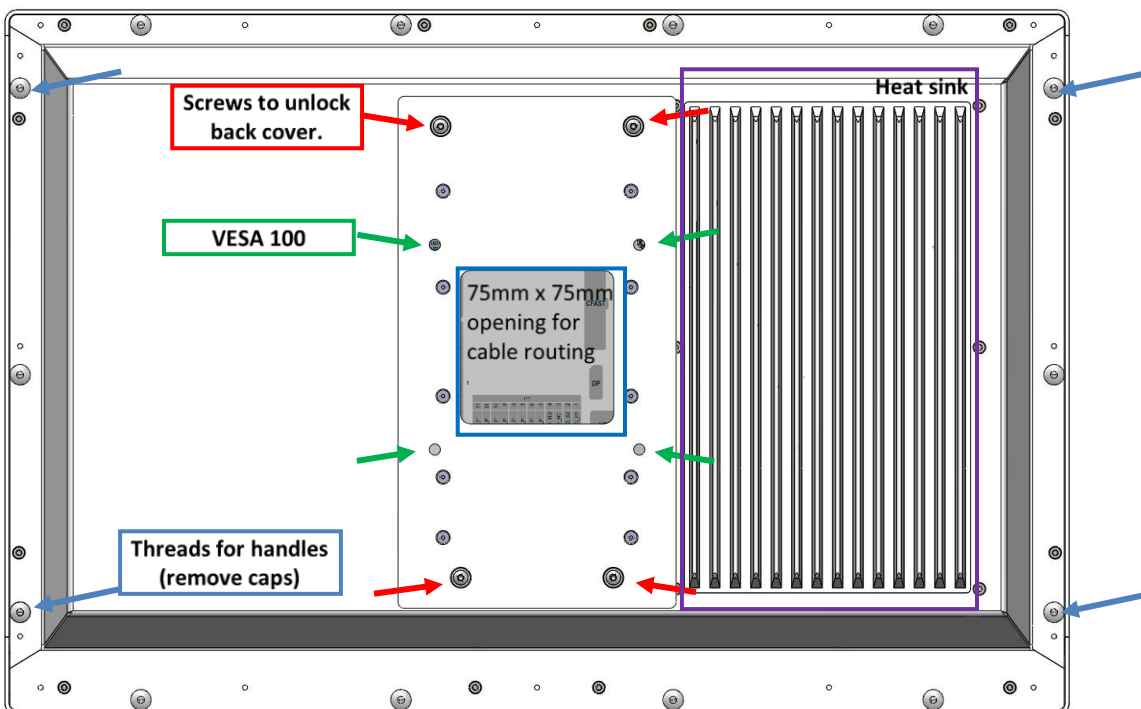

### 3.3 Position of Interface Connectors

#### 3.3.1 Right Side/ Mainboard Side/ Under the Heatsink

On both sides under the VESA mount cover are interface connectors. The mainboard is on the right side (back side view) and all interfaces directly on the AGE-X5.1 mainboard are on the **right side**.

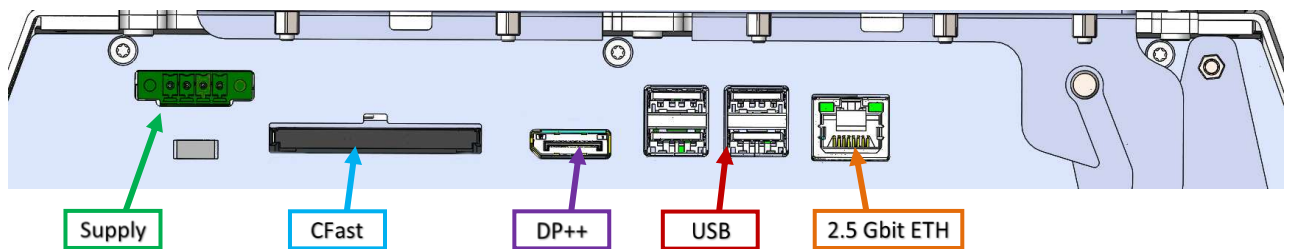

Figure 1: Right Side Interfaces

These interfaces are the same in all Vision Box Touch models based on the AGE-X5.1 mainboard.

#### 3.3.2 Left Side

On the **left side** are additional interfaces vary in different configurations. The two Gbit Ethernet interfaces are common to most configurations.

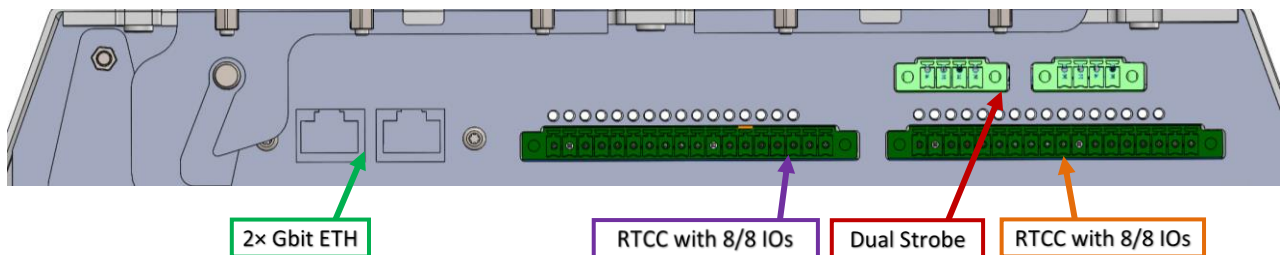

Figure 2: Left Side Interfaces

### 3.4 Basic features

In the table below there are the basic IOs and features that are available in every Vision Box Touch. All Interfaces in this table are on the **right side** except display and front USB.

	Detail
<b>CPU</b>	Intel® Pentium G6400TE, Intel® Core i5-10500TE or Intel® Core i7-10700TE
<b>RAM</b>	up to 64 GB
<b>Chipset</b>	Intel® Q470E
<b>Storage</b>	1× CFAST SSD 1× M.2 2280 M-key (not accessible by the user, optional)
<b>USB</b>	4× USB 3.2, 1× USB C 2.0 on front panel
<b>Integrated Display</b>	54.5cm (21.5"), 1920×1080, 500cd/m <sup>2</sup>
<b>Touchscreen</b>	Capacitive, 10 Fingers Multi-Touch
<b>External Display</b>	DP++: Resolution up to 4096×2304 @60Hz
<b>Ethernet (single)</b>	Intel® i225LM PCIe (10/100/1000/2.5G speeds)
<b>Interfaces for Expansion</b>	1× miniPCIe Socket, 3× internal USB 2.0 (not accessible by the user), 1× SATA

**Table 1:** Basic Features Overview

All other interfaces are connected via miniPCIe or internal USB listed in the last line of Table 1.

### 3.5 Possible Configurations

All expansion interfaces are on the **left side** except a possible RFID reader, that is placed inside the front frame.

#### 3.5.1 Dual Gbit, RTCC with 8× I/Os

Function	Internal Interface	Detail
Ethernet	miniPCIe	2× Intel® i210 PCIe (10/100/1000 speeds)
RTCC	First internal USB 2.0	8× In/ 8× Out isolated
	Second internal USB 2.0	Unused
	Third internal USB 2.0	Unused
	SATA	Unused

**Table 2:** Configuration 2×Gbit Ethernet, 8/8 digIO

#### 3.5.2 Dual Gbit, RTCC with 8× I/Os, 4× RS232

Function	Internal Interface	Detail
Ethernet	miniPCIe	2× Intel® i210 PCIe (10/100/1000 speeds)
RTCC	First internal USB 2.0	8× In/ 8× Out isolated
Quad Com Port	Second internal USB 2.0	Quad USB UART FT4232H 4× RS232 transceiver and D-Sub 9
	Third internal USB 2.0	Unused
	SATA	Unused

**Table 3:** Configuration 2×Gbit Ethernet, 8/8 digIO and 4× RS232

#### 3.5.3 Dual Gbit, RTCC with 16× I/Os, 2× Strobe and Camera Trigger

Function	Internal Interface	Detail
Ethernet	miniPCIe	2× Intel® i210 PCIe (10/100/1000 speeds)
First RTCC	First internal USB 2.0	8× In/ 8× Out isolated 2× Strobe, 2× Camera Trigger
Second RTCC	Second internal USB 2.0	8× In/ 8× Out isolated
	Third internal USB 2.0	Unused
	SATA	Unused

**Table 4:** Configuration 2×Gbit Ethernet, 2× 8/8 digIO, 2× Strobe and Camera Trigger

### 3.6 Block Diagram

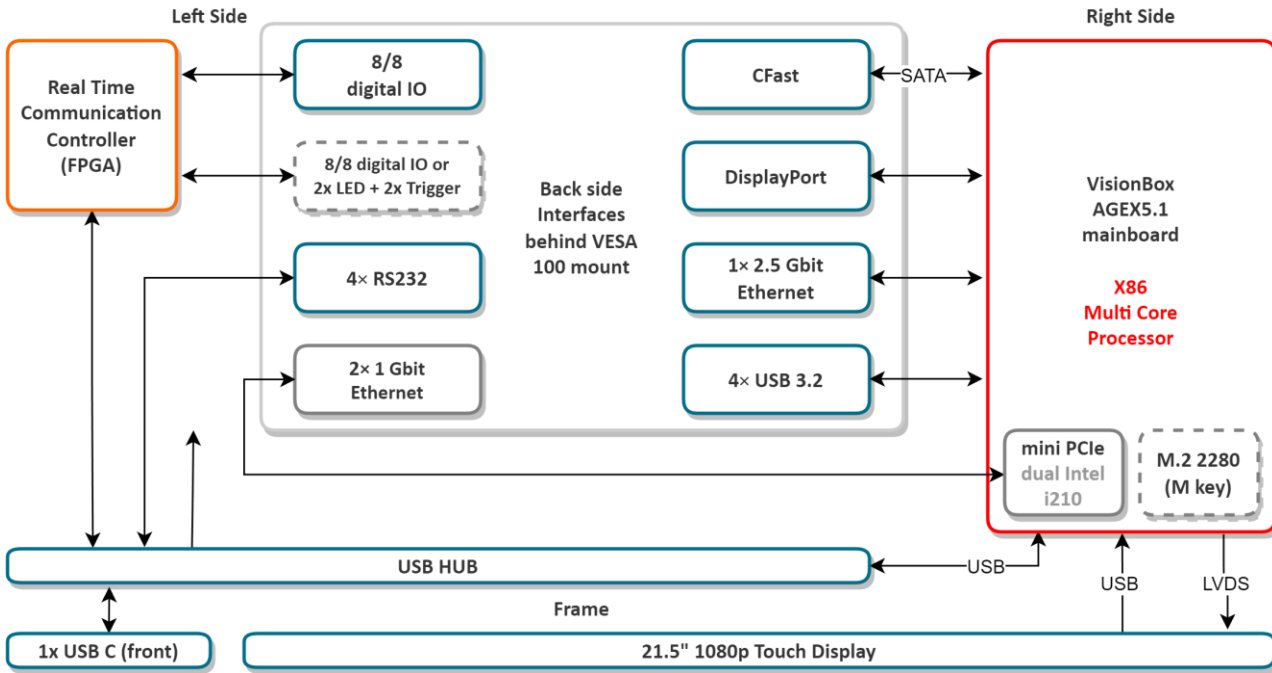

Figure 3: Block diagram for example configuration from Table 3

## 4 Technical Data

### 4.1 Processors

The following processors are currently supported:

CPU / Performance class	Pentium® Gold G6400TE / Low	Core™ i5-10500TE / Medium	Core™ i7-10700TE / High
Nominal Frequency	3.2 GHz	2.3 GHz	2.0 GHz
Turbo Frequency	3.2 GHz	3.7 GHz	4.4 GHz
Cores / Threads	2 / 4	6 / 12	8 / 16
TDP	35 W	35 W	35 W

**Table 5:** Processor overview

## 4.2 Operating Conditions

### Power supply:

Parameter	Performance class			Unit
	Low	Mid	High	
Power supply	21...30			V
Power Consumption <sup>1</sup> (at TDP workload)	tbd	72	tbd	W
Power Supply Current Rating <sup>2</sup>				
Peak current, Turbo ON	tbd	5.7	tbd	A
Peak current, Turbo OFF	tbd	3.4	tbd	A
Continuous Supply Current Limit	4			A

### Environment:

Parameter	Value	Unit
Operating Temperature for Intel CPU 10 <sup>th</sup> generation	+5 ... +40	°C
Operating Humidity, relative, non-condensing	5 ... 85	%
Storage Temperature	-10 ... +70	°C
Storage Humidity, relative, non-condensing	5 ... 95	%
Device Weight	≈8.8	kg

**Note:** The maximum allowed temperature is influenced by the actual hardware configuration, the system workload and the mounting situation. The temperature range should be verified for each application.

**Note:** Due to the lifetime of electronic components, we recommend not to operate the device permanently under the maximum possible temperature and instead use a lower than max temperature. Laws of physics say: if the average operating temperature is increased by 7°C, the lifespan of an electronic component will be divided in half!

<sup>1</sup> Measured with CPU at TDP workload and without external devices except 1× Ethernet, internal display brightness 100%.

<sup>2</sup> Measured with CPU at full workload; 24 V supply voltage; no external devices except 1× Ethernet link at 1000 Mbit/s. This value does not account for additional current drawn by interfaces like 2× Ethernet or for the supply of LED units and USB devices.

**Digital Input:**

Parameter	Min.	Typ.	Max.	Unit
Input voltage range	0		30	V
Input current range (limited by internal circuit)	0		21	mA
Threshold Voltage	Standard	6	11	V
	TTL-compatible (option) <sup>3</sup>	1.8	2.4	
Threshold current		1	5	mA
Input delay			250	ns

**Digital Output:**

Parameter	Min.	Typ.	Max.	Unit
Common VCC Supply Voltage ( $V_{CC} - V_{OUT}$ )	0		30	V
Output Current, Saturated Operation ( $V_{CC} - V_{OUT} < 1 V$ )			10	mA
Turn-On Time (24 V Common VCC, 10 mA)		5		$\mu s$
Turn-Off Time (24 V Common VCC, 10 mA)		15		$\mu s$

**LED Controller:**

Parameter <sup>4</sup>	Min.	Typ.	Max.	Unit
Strobe Current Range	0.05		6	A
Strobe Current Step Size		30		mA
Maximum Continuous Current ( $V_{Supply}=28 V, V_{Load}=24 V$ )		0.5		A
Minimum Flash Duration @ 2 A		10		$\mu s$
Flash Duration Step Size		1		$\mu s$
Turn-on delay (6 A)		3		$\mu s$
Turn-on delay (100 mA)		80		$\mu s$
Turn-off Delay (6 A)		2		$\mu s$
Turn-off Delay (100 mA)		50		$\mu s$

**Camera Trigger:**

Parameter	Min.	Typ.	Max.	Unit
ACQ TRG High Voltage		24		V
ACQ TRG Low Voltage		0.5		V
ACQ TRG High Side Current		20		mA
ACQ TRG Maximum Low Side Sink Current		100		mA

<sup>3</sup> TTL-compatible option is only available for the second I/O module

<sup>4</sup> The maximum current and strobe timing limits are calculated by the software, depending on the used parameters.

### 4.3 Dimensions

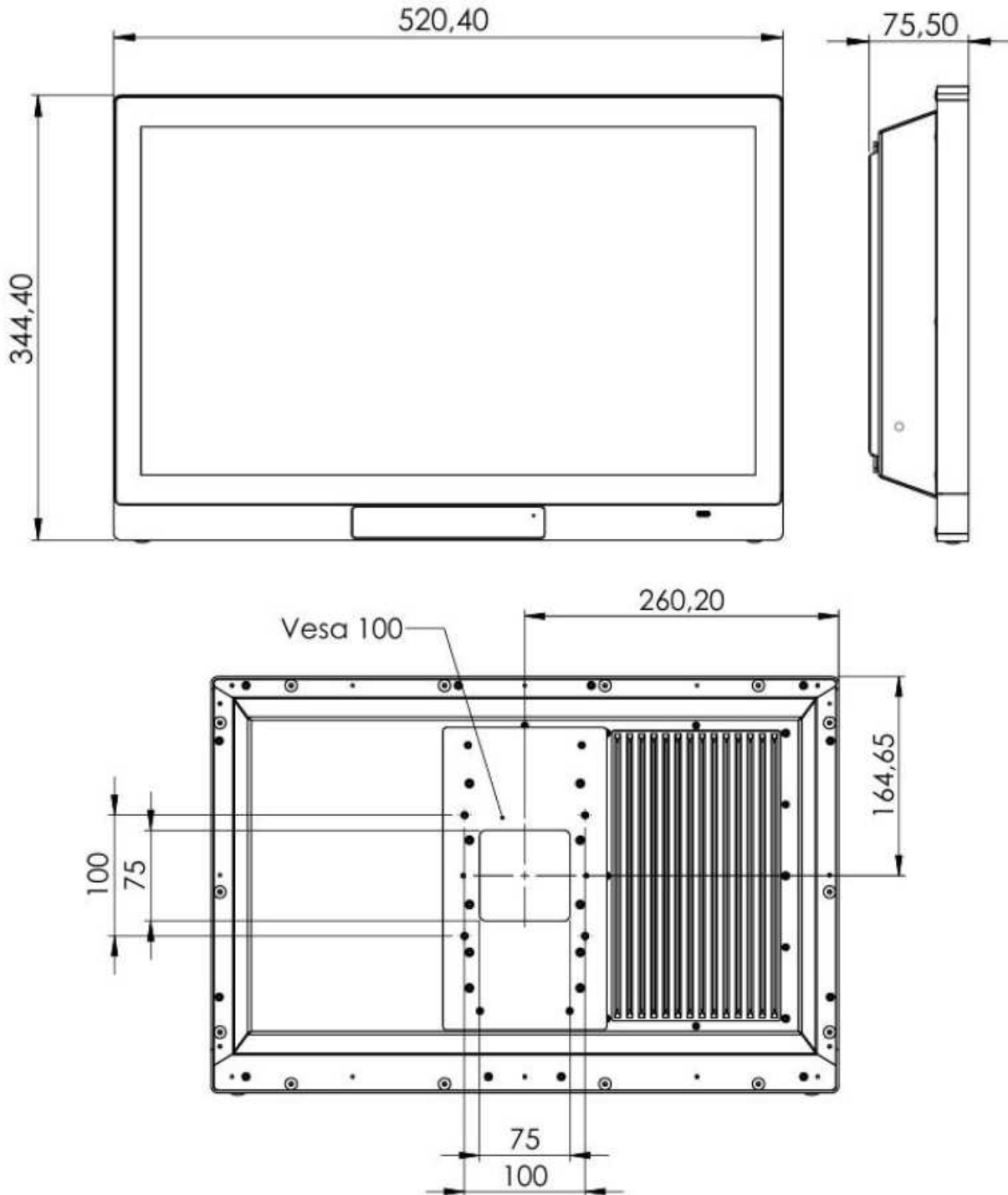

**Figure 4:** Housing dimensions (in mm)

## 5 Power Connector – Right Side

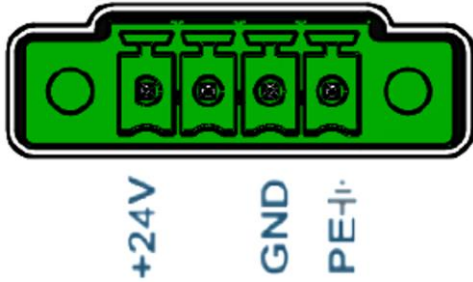

Figure 5: Power plug

Pin	Function
+24V	24 V power supply
	No function
GND	Ground
PE	Shield / housing connection

Table 6: Power connector

The  $\overline{\text{RST}}$  terminal can be pulled to GND to reset the Vision Box during operation. A falling edge will trigger the reset. Leaving the signal floating is the default mode for normal operation.

Phoenix Contact plug component: **MC 1,5/4-STF-3,5** (order no. 1847071)

## 6 Interfaces

This chapter describes the interfaces for the Vision Box Touch.

### 6.1 Ethernet Interface - Right Side (Single)

The single Ethernet interface is present for all hardware configurations.

- 10<sup>th</sup> generation CPU: 2.5GbE (2.5GBASE-T)

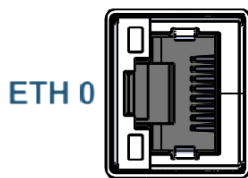

Figure 6: Ethernet connector (single)

Assignment of the status LEDs:

Link state	Upper LED
Link down	Off
Link up, no traffic	On
Link up, traffic	Blinking

Table 7: Upper LED

Link speed	10 <sup>th</sup> gen. CPU
10 Mbit/s	Off
100 Mbit/s	Off
1000 Mbit/s	Green
2500 Mbit/s	Red

Table 8: Lower LED

### 6.2 Ethernet Interface – Left Side (Dual)

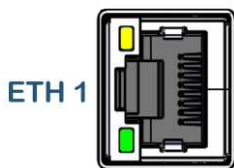
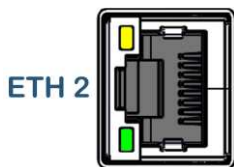

Figure 7: Ethernet connector

Link speed	Port configuration
	2x 1GigE
10 Mbit/s	Off
100 Mbit/s	Off
1000 Mbit/s	Green

Table 9: Upper LEDs

Link state	Port configuration
	2x 1GigE
Link down	Off
Link up, no traffic	Off
Link up, traffic	Blinking

Table 10: Lower LEDs

### 6.3 DisplayPort Monitor Interface – Right Side



Figure 8: DP connector

The DisplayPort interface supports version 1.2 with a data rate of 17.28 Gbit/s. The maximum supported resolution is 3840 × 2160 pixels. To connect the DP Port with a DVI or VGA monitor, an active adapter is required.

### 6.4 CFast – Right Side

The slot supports cards up to the CFast 2.0 specification with interface speeds of 6 GB/s, 3 GB/s and 1.5 GB/s. The BIOS can boot from this device, but a card hot swap is not supported. The card edge is behind a service flap which can be removed tool-free.

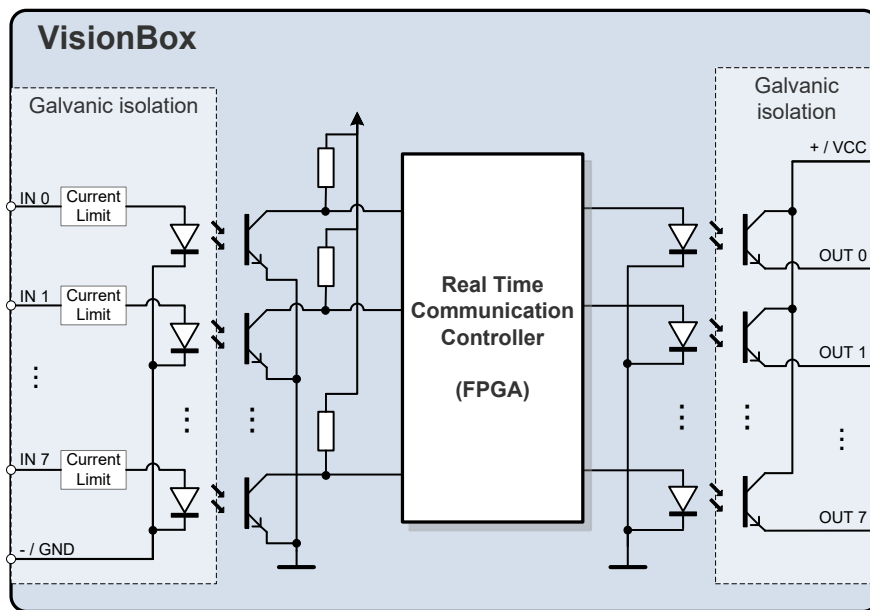

Figure 9: CFast with dust protection flap

### 6.5 Digital I/O – Left Side

The digital I/O interface provides an input group and an output group. Each group has eight signals, and all groups are electrically isolated from each other, as well as from other Vision Box circuits and interfaces.

The following illustration shows the corresponding electrical equivalent circuit for one input and one output group:



**Figure 10:** Simplified digital I/O circuit

The input group requires external connection of a shared GND reference. For the output group, the user must provide a supply voltage to the VCC pin which is used by all output signals. Every input and output have an LED to show the current state of each channel.

The connector arrangement is shown below:

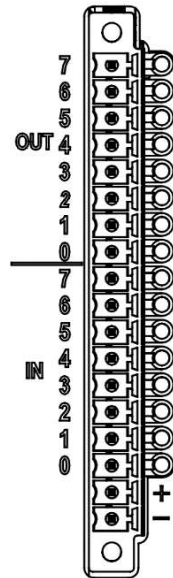

Pin	Function
+	Common VCC of outputs
-	Common GND of inputs
IN 0...7	Input 0...7
OUT 0...7	Output 0...7

**Table 11:** Pin assignment I/O connector

**Figure 11:** Digital I/O connectors

External plug component: Phoenix contact **MC 1,5/18-STF-3,5** (order no. 1847288)

The standard version of the digital output interface allows high-speed signaling, but with limited current ability. The output current can be increased by connecting multiple output terminals with each other. Software must configure the Real-Time Communication Controller to use the same signal source for these outputs.

A high-current hardware option for the digital outputs is also available. See section 4.2 Operating Conditions for electrical specifications.

**Example 1:** Connecting multiple cameras to a single output with high-current option.

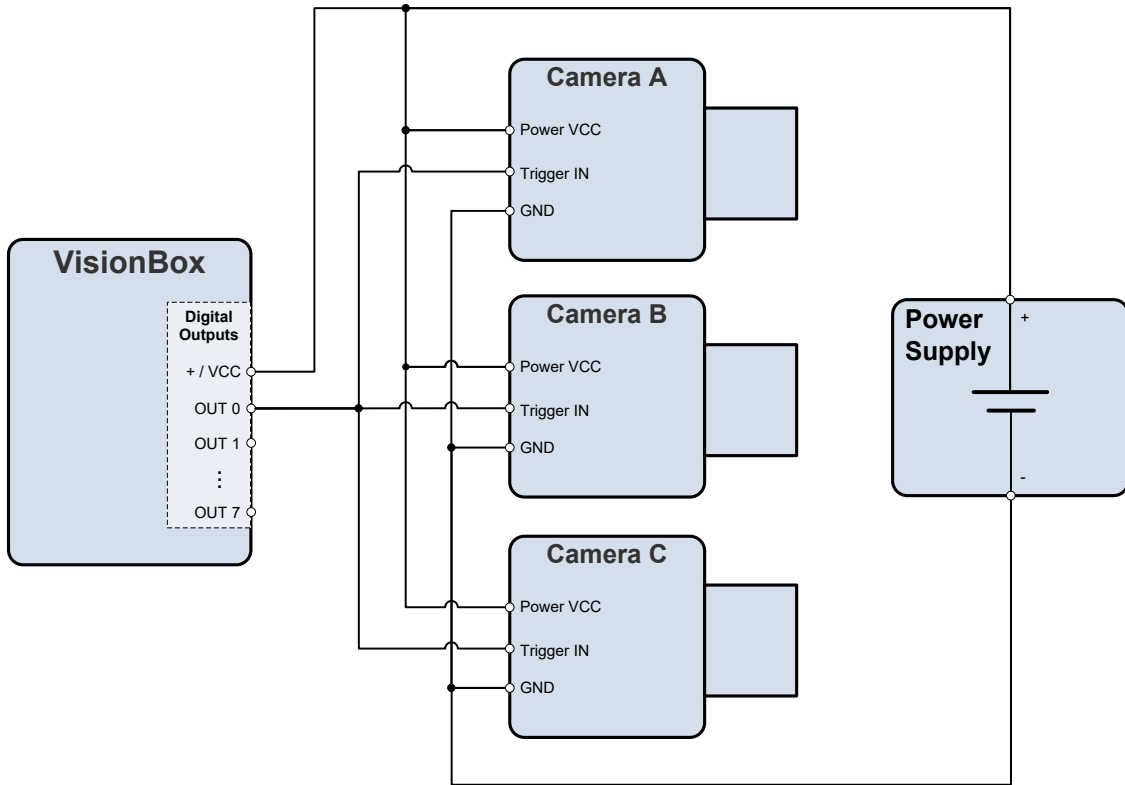

**Figure 12:** Digital I/O example 1

Depending on the voltage and isolation requirements of the application, the Vision Box can be powered from the same or from a different power supply.

**Example 2:** Connecting a relay to an output with high-current option.

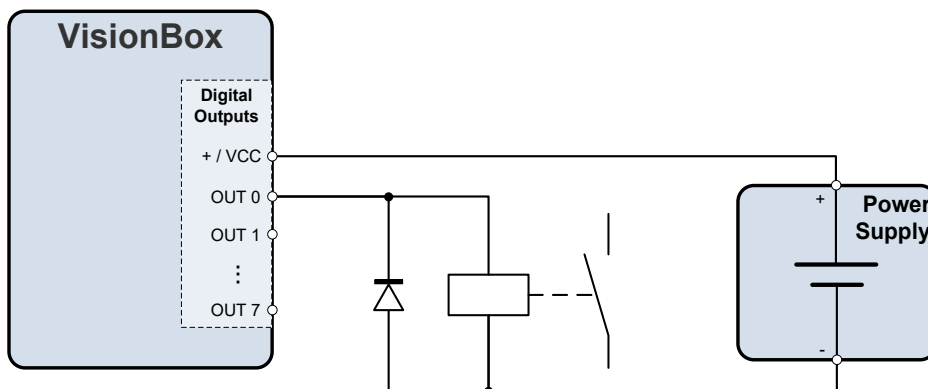

**Figure 13:** Digital I/O example 2

Please note that a flyback diode as shown in the drawing should be used to protect the output circuit from voltage spikes at deactivation.

## 6.6 LED Controller and Camera Trigger – Left Side

The Vision Box provides two LED Controller channels and two Camera Trigger channels. Each connector shares one LED Controller and one Camera Trigger channel.

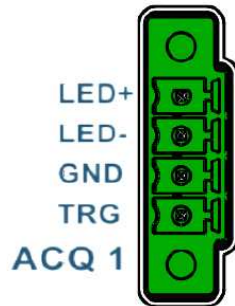

Figure 14: LED / Camera Trigger connector

Name	Function
LED+	Positive output / current source
LED-	Negative output / current sink
GND	Ground reference
TRG	Trigger output

Table 12: Pin assignment LED / Camera Trigger

Phoenix contact plug component: **MC 1,5/4-STF-3,5** (order no. 1847071)

### 6.6.1 LED Controller

The LED Flash Controller is designed as a current source. Output current, flash duration and other parameters can be set via software.

The following diagram shows the internal structure for the LED Controller:

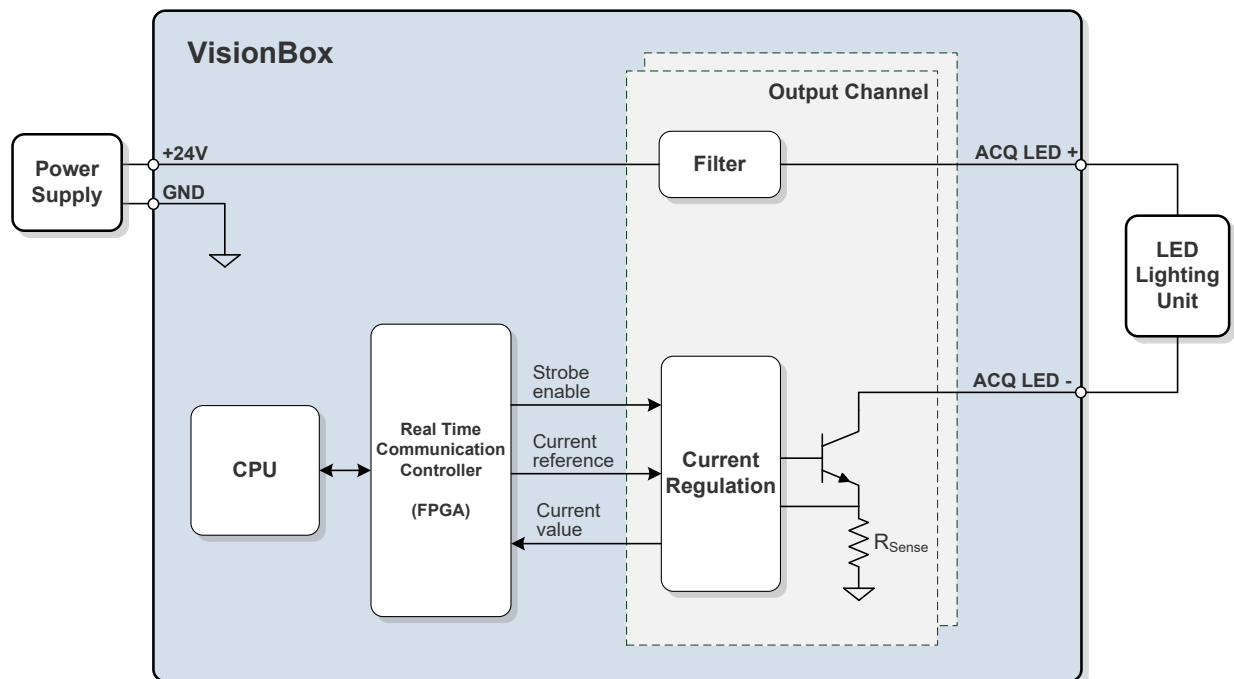
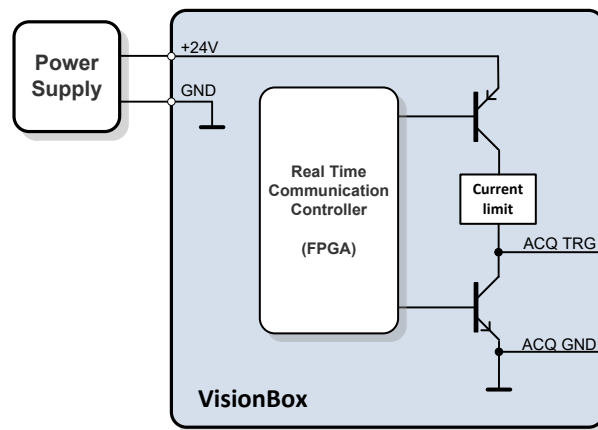

Figure 15: LED Controller structure

### 6.6.2 Camera Trigger

The electrical behavior of the camera trigger output can be controlled via software. Each output has two transistors, one for the positive and one for the negative side. Both transistors can be programmed independently. Therefore, the output can be configured in push-pull, open-collector or emitter-follower configuration:



**Figure 16:** Simplified camera trigger diagram

The high-side switch is connected to the power supply voltage of the VisionBox and has a current-limiting circuit.

## 7 Accessories

This list shows some compatible connectors to support the device interfaces. Typically, the plugs are not included in the device package.

### 7.1 Third-party Components

Vendor:	Type:	Part Number:	Usage:
Phoenix	MC 1,5 / 4-STF-3,5	1847071	Power connector / camera trigger & LED interface
Phoenix	MC 1,5 / 18-STF-3,5	1847288	Digital In / Out

There is also a connector set with plugs available. Please refer to the following table or ask for more details.

### 7.2 IMAGO Accessories

Order Number	Description
10100071	Connector set: 1x 4 Pin power connector, 2x 18 Pin I/O
10005154	Connector set: 1x 4 Pin power connector, 1x 18 Pin I/O
10100069	Connector set: 2x 4 Pin LED/Trigger

More accessories and upgrades are available upon request.

## 8 History

Revision	Date	Changes	Initials
1.0	8.2023	First version	ab
1.1	1.2024	Updated operating conditions	ab
1.2	3.2026	Updated images to match with production release	ab